



TITLE:
**SPECIFICATION FOR
OVERHEAD LINE FITTINGS
PART 1: FITTINGS FOR 10-
300MM² CONDUCTORS**

| | |
|---------------|----------------------------|
| Doc. No. | KPLC1/6C.1/13/TSP/06/036-1 |
| Issue No. | 2 |
| Revision No. | 1 |
| Date of Issue | 2015-09-17 |
| Page 1 of 45 | |

TABLE OF CONTENTS



0.1 Circulation List

0.2 Amendment Record

FOREWORD

1. SCOPE
2. REFERENCES
3. TERMS AND DEFINITIONS
4. REQUIREMENTS
5. TESTS AND INSPECTION
6. MARKING AND PACKING
7. DOCUMENTATION

ANNEX A: SCHEDULE OF GUARANTEED TECHNICAL PARTICULARS *(to be filled and signed by the Manufacturer and submitted together with relevant copies of the Manufacturer's catalogues, brochures, drawings, technical data & calculations, sales records for past five years, four customer reference letters, details of manufacturing capacity, the manufacturer's experience, copies of complete type test reports and accreditation certificate to ISO/IEC 17025 for the third party testing laboratory for tender evaluation, all in English Language)*

| | |
|---|--|
| Issued by: Head of Section, Standards | Authorized by: Head of Department, Standards |
| Signed:  | Signed:  |
| Date: 2015-09-17 | Date: 2015-09-17 |



TITLE:
**SPECIFICATION FOR
 OVERHEAD LINE FITTINGS
 PART 1: FITTINGS FOR 10-
 300MM² CONDUCTORS**

| | |
|---------------|----------------------------|
| Doc. No. | KPLC1/6C.1/13/TSP/06/036-1 |
| Issue No. | 2 |
| Revision No. | 1 |
| Date of Issue | 2015-09-17 |
| Page 2 of 45 | |

0.1 Circulation List

| COPY NO. | COPY HOLDER |
|---|--------------------|
| 1 | Manager, Standards |
| Electronic copy (pdf) on KPLC server currently: http://172.16.1.40/dms/browse.php?ffFolderId=23 | |

0.2 Amendment Record

| Rev No. | Date (YYYY-MM-DD) | Description of Change | Prepared by (Name & Signature) | Approved by (Name & Signature) |
|-------------------|-------------------|--|--------------------------------|--------------------------------|
| Issue 2 Rev 0 | 2011-12-28 | Added 300mm ² AAAC in clause 4.2.1 and 24.71mm diameter in clause 4.3.3.1 | Geoffrey Gathige | G. Owuor |
| Issue 2 Rev. 1 | 2015-09-17 | Replace issue 2 Rev 0 and includes new standards of manufacture | M. Apudo N. Wairimu | Dr. Eng. Peter Kimemia |
| | | | | |
| | | | | |

| | |
|---------------------------------------|--|
| Issued by: Head of Section, Standards | Authorized by: Head of Department, Standards |
| Signed: | Signed: |
| Date: 2015-09-17 | Date: 2015-09-17 |



TITLE:
**SPECIFICATION FOR
OVERHEAD LINE FITTINGS
PART 1: FITTINGS FOR 10-
300MM² CONDUCTORS**

| | |
|---------------|----------------------------|
| Doc. No. | KPLC1/6C.1/13/TSP/06/036-1 |
| Issue No. | 2 |
| Revision No. | 1 |
| Date of Issue | 2015-09-17 |
| Page 3 of 45 | |

FOREWORD

This specification has been prepared by the Standards Department of The Kenya Power and Lighting Company Limited (KPLC) and it lays down requirements for overhead line fittings for 10-300mm² conductors and cables. The specification is to be used by KPLC in procurement of the items.

The bidder shall submit information which confirms the manufacturer's satisfactory service experience with products which fall within the scope of this specification.

1. SCOPE

- 1.1 This specification is for overhead line fittings for use on overhead power lines operating at voltages up to and including 66 kV (66,000 Volts) a.c. 50Hz.
- 1.2 This specification covers the following overhead line fittings:-
- (a) Conductor terminations.
 - (b) Joints (Non-tension joints).
 - (c) Suspension clamps.
 - (d) Connectors (Line Taps)

Particular requirements for each type of fittings as may be relevant for a specific requisition are given in clause 4.



The specification also covers inspection and test of the overhead line fittings as well as schedule of Guaranteed Technical Particulars to be filled, signed by the manufacturer and submitted for tender evaluation.

The specification stipulates the minimum requirements for overhead line fittings acceptable for use in the company and it shall be the responsibility of the Supplier and Manufacturer to ensure adequacy of the design, good workmanship and good engineering practice in the manufacture of the fittings for KPLC.

The specification does not purport to include all the necessary provisions of a contract.

2. REFERENCES

The following standards contain provisions which, through reference in this text constitute provisions of this specification. Unless otherwise stated, the latest editions (including amendments) apply and shall be complied with by the supplier.

| | |
|---|---|
| Issued by: Head of Section, Standards | Authorized by: Head of Department, Standards |
| Signed:  | Signed:  |
| Date: 2015-09-17 | Date: 2015-09-17 |



TITLE:
**SPECIFICATION FOR
OVERHEAD LINE FITTINGS
PART 1: FITTINGS FOR 10-
300MM² CONDUCTORS**

| | |
|----------------------|----------------------------|
| Doc. No. | KPLC1/6C.1/13/TSP/06/036-1 |
| Issue No. | 2 |
| Revision No. | 1 |
| Date of Issue | 2015-09-17 |
| Page 4 of 45 | |

- ISO 1461: Metallic Coatings – Hot dip galvanized coatings on fabricated ferrous products – Requirements.
- ISO 4948-1: Steel - Classification - Part 1: Classification of steels into unalloyed and alloy steel based on chemical composition
- ISO 9477: High strength cast steels for general engineering and structural purposes
- ISO 643: Steels Micrographic determination of the apparent grain size
- ISO 6506-1; Metallic materials - Brinell hardness test - Part 1: Test method
- IEC 61284: Overhead Lines – Requirements and Test for Fittings.
- IEC 60120: Dimensions of ball and socket couplings of string insulator units
- IEC 60372: Locking devices for ball and socket couplings of string insulator units — Dimensions and tests
- BS EN 515: Aluminium and aluminium alloys. Wrought products. Temper designations.
- BS EN 755-2: Aluminium and aluminium alloys. Extruded rod/bar, tube and profiles. Mechanical properties.
- BS EN 586-1&2: Aluminium and Aluminium alloys-Forging. –Part 1: Technical conditions for inspection and delivery; -- Part 2: Mechanical properties and additional property requirements
- BS EN 573-3&4: Aluminium and aluminium alloys-Chemical composition and form of wrought products.—Part 3: Chemical composition; Part 4: Forms of products.
- BS 3288-1, 2&3: Insulator and conductor fittings for overhead power lines. –Part 1: Performance and General Requirements; –Part 2: Specification for a range of insulator fittings
- BS EN 10090: Valve steels and alloys for internal combustion engines
- DIN 74-1: Countersinks for countersunk head screws
- DIN 48072-1&2: Line taps – Part 1: Stranded aluminium conductors and ACSR; Part 2: Stranded copper conductors and solid ones
- ENA TS 43-92: Overhead Line Fittings

Issued by: Head of Section, Standards

Authorized by: Head of Department, Standards

Signed:

Signed:

Date: 2015-09-17

Date: 2015-09-17



TITLE:
**SPECIFICATION FOR
OVERHEAD LINE FITTINGS
PART 1: FITTINGS FOR 10-
300MM² CONDUCTORS**

| | |
|---------------|----------------------------|
| Doc. No. | KPLC1/6C.1/13/TSP/06/036-1 |
| Issue No. | 2 |
| Revision No. | 1 |
| Date of Issue | 2015-09-17 |
| Page 5 of 45 | |

AWS D1.2/D1.2M: Structural Welding Code – Aluminum

3. TERMS AND DEFINITIONS

The definitions given in the reference standards apply.

4. REQUIREMENTS

4.1. SERVICE CONDITIONS

The fittings shall be suitable for continuous operation outdoors in tropical areas

- a) At altitudes of up to 2200m above sea level,
- b) Humidity of up to 90%,
- c) Average ambient temperature of +30°C with a minimum of -1°C and a maximum of +40°C and
- d) Heavy saline conditions along the coast.

4.2. GENERAL REQUIREMENTS



4.2.1. The fittings shall be designed and manufactured to IEC 61284, BS 3288-2:2009 and the requirements of this specification and shall be suitable for use on

- a) 25-150mm² Aluminium Conductor Steel Reinforced (ACSR),
- b) 50-100mm² All Aluminium Conductor (AAC)
- c) 50-300mm² All Aluminium Alloy Conductor (AAAC),
- d) 16-300mm² Aluminium Cables
- e) 10-120mm² Copper Conductor/Cables (tap).

4.2.2. The fittings shall be free from defects which would likely cause them to be unsatisfactory in service.

4.2.3. All parts of each fitting shall be inherently resistant to atmospheric corrosion, both during storage and in service.

4.2.4. All ferrous metal parts except those made of stainless steel shall be protected by hot dip galvanizing as per the requirement of ISO 1461. The minimum average coating thickness shall be 85µm for flats articles and 50µm for centrifuged articles in accordance with ISO 1461.

| | |
|---|---|
| Issued by: Head of Section, Standards | Authorized by: Head of Department, Standards |
| Signed:  | Signed:  |
| Date: 2015-09-17 | Date: 2015-09-17 |



TITLE:
**SPECIFICATION FOR
OVERHEAD LINE FITTINGS
PART 1: FITTINGS FOR 10-
300MM² CONDUCTORS**

| | |
|---------------|----------------------------|
| Doc. No. | KPLC1/6C.1/13/TSP/06/036-1 |
| Issue No. | 2 |
| Revision No. | 1 |
| Date of Issue | 2015-09-17 |
| Page 6 of 45 | |

- 4.2.5. Bolts and nuts shall be made from stainless steel which shall fulfill the requirements of quality A2-80 according to ISO 3506. The mechanical properties shall conform to ISO 889-1 and ISO 898-2.
- 4.2.6. The threads of bolts, nuts and tapped holes shall be cut and shall be well oiled or greased. All other threads shall be formed before galvanizing. The thread design shall be triangular ISO thread in accordance with ISO 68-1; diameter/pitch combinations in accordance with ISO 262 and thread tolerance class of 6g as per ISO 965-2, for coarse tolerance quality.
- 4.2.7. Washers shall provide sufficient resistance to corrosion and shall be made from stainless steel with a minimum quality equivalent to A2 of ISO 3506. Washers shall have a minimum hardness of 240 HBW.
- 4.2.8. General arrangement drawings for the various types of fittings are attached in Annex B of this specification. Drawings for fittings shall be as per BS 3288-2 Reference Numbers are available in the standard, ENA TS 43-92 and KPLC code of practice.



4.3. PARTICULAR REQUIREMENTS

4.3.1. Conductor Terminations

4.3.1.1. Ball Ended Hook, Ball clevis, Socket Clevis and Socket Tongue

4.3.1.1.1. Design and construction

- 4.3.1.1.1.1. Ball ended hook, socket clevis and socket tongue shall be suitable for use on Aluminium Conductor Steel Reinforced (ACSR) of outer diameter between 7.00mm and 18.2mm (25mm² and 150mm²) and All Aluminium Alloy Conductor (AAAC) of outer diameter approximately 24.71, with standard disc insulator of ball and socket type with the ball pin diameter of 16 mm in accordance with Fig. 1 & 2 as per IEC 60120.
- 4.3.1.1.1.2. Socket type fittings shall be supplied complete with locking devices such as split pins and security clips in accordance with BS 3288-4 and clause 4.3.1.1.4
- 4.3.1.1.1.3. Ball ended hook, socket clevis and socket tongue shall be as per BS 3288 Reference Numbers given in Table 1:

| | |
|---|---|
| Issued by: Head of Section, Standards | Authorized by: Head of Department, Standards |
| Signed:  | Signed:  |
| Date: 2015-09-17 | Date: 2015-09-17 |



TITLE:
**SPECIFICATION FOR
OVERHEAD LINE FITTINGS
PART 1: FITTINGS FOR 10-
300MM² CONDUCTORS**

| | |
|----------------------|----------------------------|
| Doc. No. | KPLC1/6C.1/13/TSP/06/036-1 |
| Issue No. | 2 |
| Revision No. | 1 |
| Date of Issue | 2015-09-17 |

Table 1: Reference numbers as per BS 3288-2

| Description | BS 3288 Reference Number |
|----------------------------|---------------------------------|
| Ball ended hook | 15/81 |
| Ball clevis | 15/83 |
| Socket clevis, single hole | 15/84 |
| Sock clevis, double hole | 15/25 |
| Socket tongue, single hole | 15/85 |
| Socket tongue, double hole | 15/35 |

NOTE: Drawings for Ball Ended Hook, Socket Clevis and Socket Tongue shall be as per BS 3288-2 and ANNEX B.



4.3.1.1.2. Material of manufacture

- 4.3.1.1.2.1. The steel used to manufacture ball ended hook, socket clevis and socket tongue shall be produced by an electric, or by an oxygen-blown, process. The manufacturer shall submit a cast analysis of the steel with the bid for purposes of tender evaluation.
- 4.3.1.1.2.2. The steel shall be fully killed, suitable for forging and capable of being heat treated to obtain the mechanical properties required by this specification.
- 4.3.1.1.2.3. The steel shall contain at least two of the following elements in the alloying proportions specified in ISO 4948-1:
- a) Nickel ;
 - b) Chromium;
 - c) Molybdenum.

Its content of sulfur and phosphorus shall be restricted in accordance with Table 2.

Table 2: Contents of sulphur and phosphorous in forged steel

| Element | Maximum content (% by mass) determined by | |
|----------------|--|-----------------------|
| | Cast analysis | Check analysis |
| Sulphur | 0.025 | 0.03 |
| Phosphorous | 0.025 | 0.03 |

| | |
|--|--|
| Issued by: Head of Section, Standards | Authorized by: Head of Department, Standards |
| Signed:  | Signed:  |
| Date: 2015-09-17 | Date: 2015-09-17 |



TITLE:
**SPECIFICATION FOR
OVERHEAD LINE FITTINGS
PART 1: FITTINGS FOR 10-
300MM² CONDUCTORS**

| | |
|----------------------|-----------------------------------|
| Doc. No. | KPLC1/6C.1/13/TSP/06/036-1 |
| Issue No. | 2 |
| Revision No. | 1 |
| Date of Issue | 2015-09-17 |
| Page 8 of 45 | |

- 4.3.1.1.2.4. The steel shall be made in conformity with fine grain practice in order to obtain an austenitic grain size of 5 or finer when tested in accordance with ISO 643. This could be achieved, for example, by ensuring that it contains sufficient aluminium or an equivalent element to permit the manufacture of the steel forgings stabilized against strain-age embrittlement during service; a minimum value of 0.025 % of total aluminium is given for guidance.
- 4.3.1.1.2.5. Within the limitations specified above, it is the responsibility of the manufacturer to select steel such that the finished steel forgings, suitably heat-treated, comply with the requirements for mechanical properties of this specification.
- 4.3.1.1.2.6. Each component shall be hardened from a temperature above the AC3 point and tempered before being subjected to the manufacturing proof force. The tempering temperature shall be a minimum of 400 °C. The tempering conditions shall be at least as effective as a temperature of 400 °C maintained for a period of 1 h.
- 4.3.1.1.2.7. Surface hardening shall not be permitted for load bearing parts of the component. The surface hardness shall not exceed 380 HBS measured in accordance with ISO 6506-1.
- 4.3.1.1.2.8. The material for the fasteners (bolts, nuts and washers) for the ball ended hook, socket clevis and socket tongue shall be as per clauses 4.2.5 – 4.2.7 of this specification.

4.3.1.1.3. Dimensional requirements for ball and socket.

The dimensional requirements for the ball and socket shall be as per the Figure 1 & 2 and as per IEC 60120 and IEC 60372.

Issued by: Head of Section, Standards

Authorized by: Head of Department, Standards

Signed:

Signed:

Date: 2015-09-17

Date: 2015-09-17

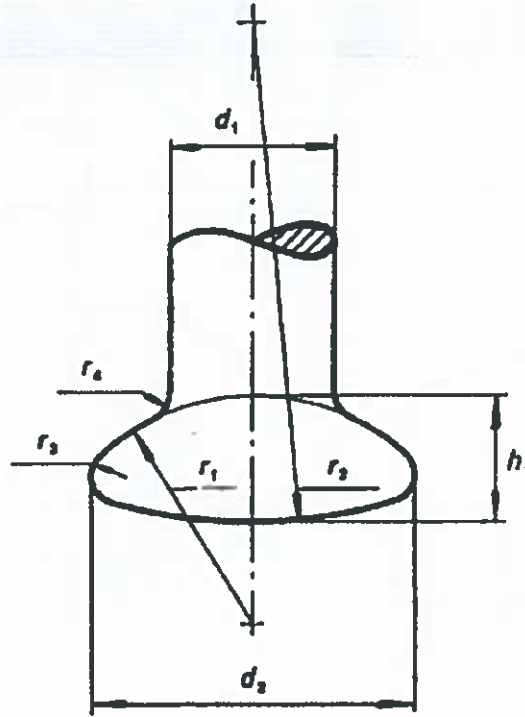

Fig. 1: Ball

Table 3: Dimensions of the ball as per IEC 60120

| Designated coupling size | d ₁ | d ₂ | h ₁ | r ₁ | r ₂ | r ₃ [*] | r ₄ |
|--------------------------|---------------------------------|-----------------------------------|-----------------------------------|----------------|----------------|-----------------------------|---------------------------------|
| 16 | 17 ⁰ _{-1.2} | 33.3 ⁰ _{-1.5} | 13.4 ⁰ _{-1.3} | 23 | 50 | 3 | 3 ⁺¹ _{-0.5} |
| 20 | 21 ⁰ _{-1.3} | 41 ⁰ _{-1.6} | 19.5 ⁰ _{-1.4} | 27 | 60 | 5.7 | 3.5 ⁺¹ ₋₁ |

Issued by: Head of Section, Standards

Signed:

Date: 2015-09-17

Authorized by: Head of Department, Standards

Signed:

Date: 2015-09-17

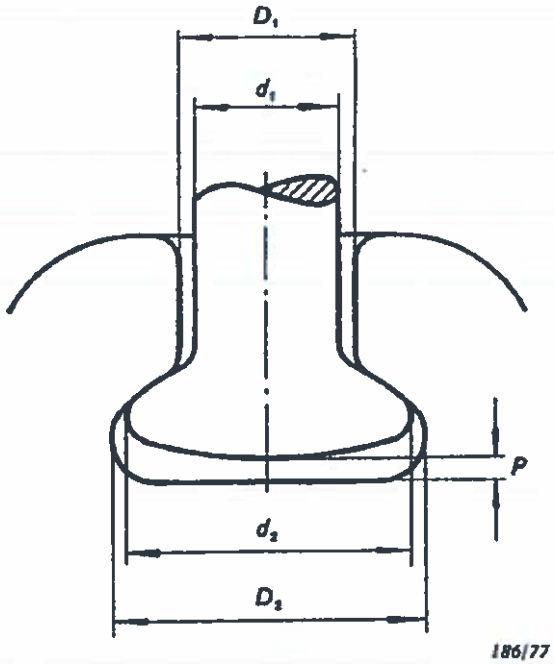

The pin ball in the socket entry.

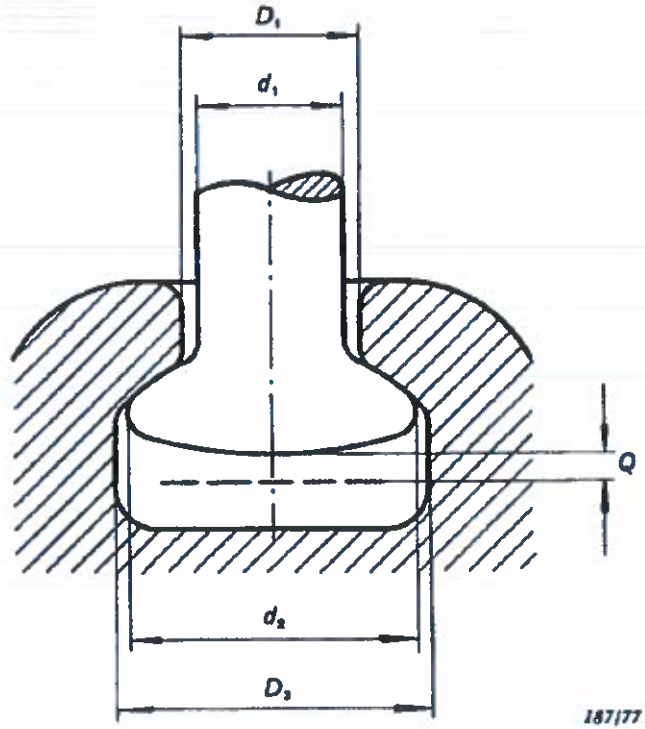

The pin ball in the socket interior.

Fig. 2: Ball & Socket

Table 4: Clearance between the pin ball and the socket end as per IEC 60120

| Designated size of coupling | D ₁ – d ₁ | | D ₂ – d ₂ | D ₃ – d ₂ | P | | Q ¹⁾ |
|-----------------------------|---------------------------------|------|---------------------------------|---------------------------------|------|------|-----------------|
| | Min | Max. | Min. | | Min. | Max. | Min. |
| 16B | 2.2 | 5.0 | 1.2 | 1.2 | 3.6 | 6.5 | 3.7 |
| 20 | 2.0 | 5.4 | 1.5 | 1.5 | 1.0 | 4.5 | 2.0 |

¹⁾ Clearance between the pin ball and the locking device

4.3.1.1.4. Locking devices for ball and socket couplings

4.3.1.1.5. These devices shall have standard dimensions and tested as per IEC 60372 for the ball and socket sizes in Table 3 & 4.

Issued by: Head of Section, Standards

Authorized by: Head of Department, Standards

Signed:



Signed:



Date: 2015-09-17

Date: 2015-09-17

4.3.1.1.6. The locking devices shall be made of austenitic stainless steel capable of complying with the requirements relating to intercrystalline corrosion test of BS EN 10090.

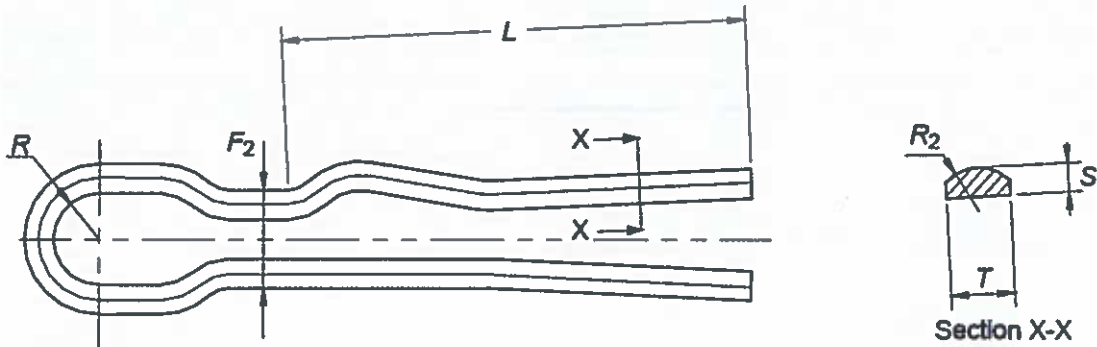

Fig. 3: Split pin

Table 5: Standard dimensions for the split pins as per IEC 60372

| Standard coupling | Standard split pins | | | | | |
|-------------------|---------------------|----------------------------------|----------------|--------------------|------------------|------------------|
| | S | T | R ₂ | F _{2 min} | R _{min} | L _{min} |
| 16 | 3.2 ± 0.1 | 7.9 ^{+0.2} ₀ | 4.8 | 10.7 | 3 | 38 |
| 20 | 3.2 ± 0.1 | 7.0 ^{+0.2} ₀ | 4.8 | 10.7 | 3 | 49 |

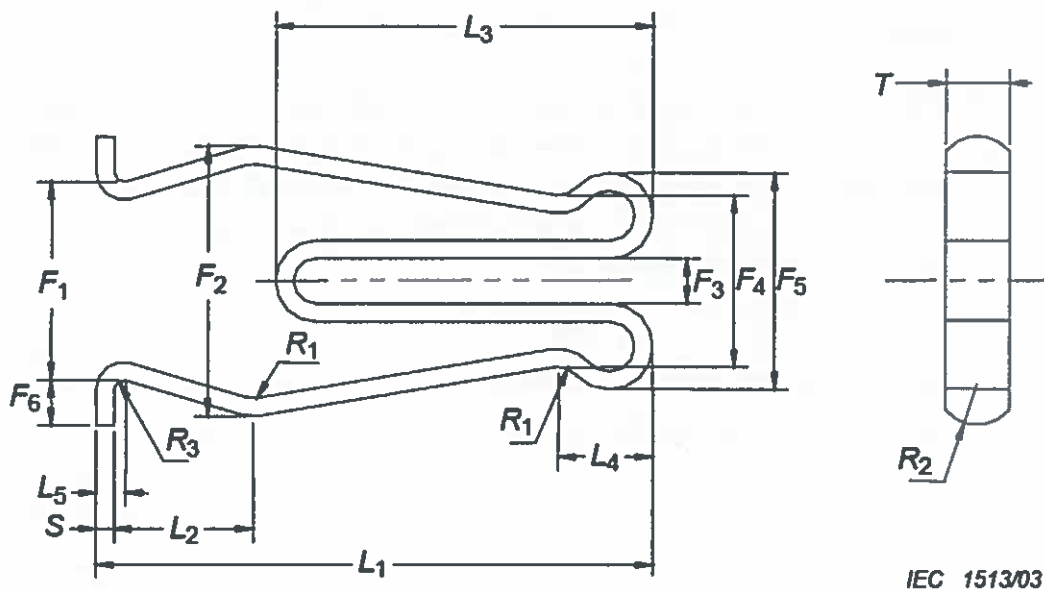

Fig. 4: Security W-Clip

IEC 1513/03



| | |
|--|--|
| Issued by: Head of Section, Standards | Authorized by: Head of Department, Standards |
| Signed:  | Signed:  |
| Date: 2015-09-17 | Date: 2015-09-17 |

Table 6: Dimensions of the W-Clips

| Standard coupling | F1 | F2 | F3 | F4 | F5 | F6 | L1 | L2 | L3 | L4 | L5 | R1 | R2 | R3 | S | T |
|-------------------|----|----|----|----|----|------------------------------|--------|------|--------|------|----|-----|-----|-----|----------------------------------|----------------------------------|
| 16B | 22 | 28 | 5 | 19 | 24 | 5 ⁺¹ ₀ | 50±1.5 | 15.5 | 36±1.5 | 10.5 | 3 | 2.5 | 4.5 | 2.5 | 1.5 ^{+0.2} ₀ | 7.9 ^{+0.2} ₀ |
| 20 | 22 | 30 | 5 | 19 | 24 | 5 ⁺¹ ₀ | 62±1.5 | 15.5 | 42±1.5 | 10.5 | 3 | 2.5 | 4.5 | 2.5 | 2.0 ^{+0.2} ₀ | 3.5 ^{+0.2} ₀ |

4.3.2. TENSION CLAMP (STRAIN CLAMP)

4.3.2.1. General

- 4.3.2.1.1. Tension (strain) Clamp shall be bolted type and shall be suitable for use on Aluminium Conductor Steel Reinforced (ACSR) of outer diameter between 5.1mm and 30.5mm (25mm² and 300mm²).
- 4.3.2.1.2. The clamp shall have cotter bolts, U-bolts and a pin. The number of bolts shall be 3, 4 or 5 (to be stated in the tender).
- 4.3.2.1.3. The clamp shall have slip strength of not less than 85% of the rated ultimate strength of conductor it is intended for use with.

4.3.2.2. Material

- 4.3.2.2.1. **The body and the keeper-** shall be manufactured from aluminium alloy containing a maximum of 0.4% Cu in accordance with EN 515 and EN 755-2:2008 such as designation 6061-T6 or equivalent. The alloy shall be resistant to inter-crystalline, layer and stress corrosion. Further properties of the alloy shall be:
- Hardness min 95 HBW,
 - Resistivity max. 40 nΩm at 20°C,
 - Proof stress min. 276 MPa
 - Tensile strength min. 310MPa.
 - A₅₀% elongation at break min. 12%.
- 4.3.2.2.2. **Threaded inserts** -To provide sufficient resistance to corrosion threaded inserts shall be made from stainless steel with a minimum quality equivalent to A2 of EN ISO 3506. The required mechanical properties shall be equivalent to those given for bolts and nuts in 4.2.5 – 4.2.6.

Issued by: Head of Section, Standards

Authorized by: Head of Department, Standards

Signed:

Signed:

Date: 2015-09-17

Date: 2015-09-17



TITLE:
**SPECIFICATION FOR
OVERHEAD LINE FITTINGS
PART 1: FITTINGS FOR 10-
300MM² CONDUCTORS**

| | |
|---------------|----------------------------|
| Doc. No. | KPLC1/6C.1/13/TSP/06/036-1 |
| Issue No. | 2 |
| Revision No. | 1 |
| Date of Issue | 2015-09-17 |
| Page 13 of 45 | |

4.3.2.2.3. **Straps** - Straps shall be made from hot-dip galvanized steel. The thickness of the zinc coating shall be at least 80µm and meet the requirements according to ISO 1461.

4.3.2.2.4. The material for the fasteners (bolts, nuts and washers) for the tension clamps shall be as per clauses 4.2.5 – 4.2.7 of this specification.

4.3.2.3. **Design**

4.3.2.3.1. **Clamp** - It shall be possible to move clamps along the conductor freely. The trunnion of the clamp may be an integral part of the body.

4.3.2.3.2. **Conductor supporting groove** - The profile of the conductor supporting groove, in the body and the keeper, shall conform to the measurements given in Figure 7 and adjacent table. The conductor groove radii in body and keeper shall be closely adjusted to the conductor diameter in question in accordance with Figure 7 and be free from irregularities and sharp edges

4.3.2.3.3. **Fatigue damages** - Clamps may not cause fatigue damage on the conductor.

4.3.2.3.4. **Straps** - The hole in the strap for the trunnion of the body shall be round and have a suitable size in relation to the trunnion.

4.3.2.3.5. **Bolts and nuts**



- Bolts and nuts shall have M12 metric threads with 18 mm width across flats according to ISO 272. Bolts and nuts shall be attached to the tension clamp in such a way that they are impossible to drop accidentally.
- Bolts shall be long enough to protrude outside the thread of the nut. Counter bores and countersinks shall be made in accordance with DIN 74-1.

4.3.2.3.6. **Washers** - Washers shall be manufactured in accordance with ISO 7091.

4.3.3. **SUSPENSION CLAMPS**

4.3.3.1. **General**

Suspension clamps design shall have the axis of oscillation in the plane of the axis of the conductor and be capable of being fitted with counter weights. They shall be used for both phase conductors and shield wires (where applicable) as well as for straight line and angle supports.

| | |
|---|---|
| Issued by: Head of Section, Standards | Authorized by: Head of Department, Standards |
| Signed:  | Signed:  |
| Date: 2015-09-17 | Date: 2015-09-17 |



TITLE:
**SPECIFICATION FOR
OVERHEAD LINE FITTINGS
PART 1: FITTINGS FOR 10-
300MM² CONDUCTORS**

| | |
|---------------|----------------------------|
| Doc. No. | KPLC1/6C.1/13/TSP/06/036-1 |
| Issue No. | 2 |
| Revision No. | 1 |
| Date of Issue | 2015-09-17 |
| Page 14 of 45 | |

4.3.3.2. Material

4.3.3.2.1. The body and the keeper- shall be manufactured from aluminium alloy containing a maximum of 0.10% Cu in accordance with EN 515 and EN 755-2:2008 such as designation 6082-T5 or equivalent. The alloy shall be resistant to inter-crystalline, layer and stress corrosion. Further properties of the alloy shall be:

- (i) Hardness min 75 HBW,
- (ii) Resistivity max. 60 nΩm at 20°C,
- (iii) Hardness min 95 HBW,
- (iv) Proof stress min. 230 MPa
- (v) Tensile strength min. 270MPa.
- (vi) A50% elongation at break min. 8%.

4.3.3.2.2. Fasteners (bolts, nuts and washers) material for the suspension clamps shall be as per clauses 4.2.5 – 4.2.7 of this specification.

4.3.3.2.3. Threaded inserts - shall be made from stainless steel with a minimum quality equivalent to A2 of EN ISO 3506 to provide sufficient resistance to corrosion. The required mechanical properties shall be equivalent to those given for bolts and nuts in Clause 4.2.5 – 4.2.6.

4.3.3.2.4. Straps - shall be made from hot-dip galvanized steel. The thickness of the zinc coating shall be at least 80µm and meet the requirements according to ISO 1461.

4.3.3.3. Design

4.3.3.3.1. The general design arrangement shall be as per the drawings in Annex B attached.

4.3.3.3.2. Clamp - It shall be possible to move clamps along the conductor freely. The trunnion of the clamp may be an integral part of the body.

4.3.3.3.3. Conductor supporting groove - The profile of the conductor supporting groove, in the body and the keeper, shall conform to the measurements given in Figure 8 & 9 and adjacent table. The conductor groove radii in body and keeper shall be closely adjusted to the conductor diameter in question and shall be free from irregularities and sharp edges

4.3.3.3.4. Fatigue damages - Clamps shall be designed not cause fatigue damage on the conductor.

Issued by: Head of Section, Standards

Authorized by: Head of Department, Standards

Signed:

Signed:

Date: 2015-09-17

Date: 2015-09-17



TITLE:
**SPECIFICATION FOR
OVERHEAD LINE FITTINGS
PART 1: FITTINGS FOR 10-
300MM² CONDUCTORS**

| | |
|---------------|----------------------------|
| Doc. No. | KPLC1/6C.1/13/TSP/06/036-1 |
| Issue No. | 2 |
| Revision No. | 1 |
| Date of Issue | 2015-09-17 |
| Page 15 of 45 | |

4.3.3.3.5. **Straps** - The hole in the strap for the trunnion of the body shall be round and have a suitable size in relation to the trunnion.

4.3.3.3.6. **Bolts and nuts**

- (i) Bolts and nuts shall have M12 metric threads with 18 mm width across flats according to ISO 272. Bolts and nuts shall be attached to the suspension clamp in such a way that they are impossible to drop accidentally.
- (ii) Bolts shall be long enough to protrude outside the thread of the nut. Counter bores and countersinks shall be made in accordance with SS 2173.

4.3.3.3.7. **Washers** - Washers shall be manufactured in accordance with ISO 7091.

4.3.3.4. **Types**

- a) **Pivoted type** (similarly known as *trunnion type* respectively) as shall be stated in the tender - may be keeper type with U-Clamps or Closed Type as per Figure 8 of Annex B.
- b) **Envelope type suspension clamp** (similarly known as *side opening type*) — may be *Clevis ended hook type*, *tongue ended hook type* as per Figure 9 of Annex B - The clamp shall be suitable for use on turning angles from 10 to 120 degrees.

NOTE: *The required type of clamp shall be stated in the tender.*

4.3.4. **NON-TENSION (BOLTED) CONNECTORS**

4.3.4.1. **Parallel Groove Clamp (PG Clamp)**

4.3.4.1.1. **General**

- 4.3.4.1.1.1. Aluminium line taps shall be designed, manufactured and tested in accordance with DIN 48072-1.
- 4.3.4.1.1.2. PG Clamp shall be suitable for use on aluminium conductor steel-reinforced, all aluminium alloy conductor, and all aluminium conductors of outer diameter 7.00 mm to 18.2 mm for ACSR, 24.71mm for AAAC, and 9.0 mm to 13.2 mm for AAC conductors.

Issued by: Head of Section, Standards

Authorized by: Head of Department, Standards

Signed:

Signed:

Date: 2015-09-17

Date: 2015-09-17

| | |
|----------------------|----------------------------|
| Doc. No. | KPLC1/6C.1/13/TSP/06/036-1 |
| Issue No. | 2 |
| Revision No. | 1 |
| Date of Issue | 2015-09-17 |
| Page 16 of 45 | |

4.3.4.1.1.3. PG Clamps shall be used to connect two parallel conductors by accommodating one in each groove. The conductors may be similar or dissimilar.

4.3.4.1.2. Materials

4.3.4.1.2.1. The PG Clamps body shall be made of Aluminium Alloy Castings / Forgings / Extrusions and shall provide a minimum of 1.2 KN slip strength. The electrical power rating shall not be less than that of the conductors

4.3.4.1.2.2. The Aluminium Alloy shall be electrolytic, high strength and corrosion resistant in accordance with EN 515, EN 755-2 and clause 4.3.3.2.1. The other component parts of the PG clamp shall have the same material quality in accordance with clause 4.3.3.2.

4.3.4.1.2.3. Fasteners (bolts, nuts and washers) material for the suspension clamps shall be as per clauses 4.2.5 – 4.2.7 of this specification.

4.3.4.1.3. Design

4.3.4.1.3.1. **Conductor supporting groove** - The profile of the conductor supporting groove, shall conform to the measurements given in Figure 10, 11 & 12 and adjacent table. The groove of the PG clamp shall correctly fit the conductor to which it is intended for its use and shall be free from irregularities and sharp edges. It shall have adequate cross sectional area and length.

4.3.4.1.3.2. **Inserts** - Connectors for joining aluminium conductor to copper conductor shall have pressure welded copper inserts in the tap-off side. The welding procedure shall conform to AWS D1.2/D1.2M, Group M23. The tap conductor shall be of size 25 – 300mm².

4.3.4.1.3.3. **Fatigue damages** - Clamps shall be designed not cause fatigue damage on the conductor.

4.3.4.1.3.4. Bolts and nuts

- (i) Bolts and nuts shall have metric threads according to ISO 272. Bolts and nuts shall be attached to the PG clamp in such a way that they are impossible to drop accidentally. It shall also be possible to tighten them from the upper side of the clamp.
- (ii) Bolts shall be long enough to protrude outside the thread of the nut. Counter bores and countersinks shall be made in accordance with SS 2173.

Issued by: Head of Section, Standards

Authorized by: Head of Department, Standards

Signed:



Signed:



Date: 2015-09-17

Date: 2015-09-17



TITLE:
**SPECIFICATION FOR
OVERHEAD LINE FITTINGS
PART 1: FITTINGS FOR 10-
300MM² CONDUCTORS**

| | |
|---------------|-----------------------------|
| Doc. No. | KPLC/1/6C.1/13/TSP/06/036-1 |
| Issue No. | 2 |
| Revision No. | 1 |
| Date of Issue | 2015-09-17 |
| Page 17 of 45 | |

4.3.4.1.3.5. Washers - Washers shall be manufactured in accordance with ISO 7091.

4.3.4.1.3.6. The number of bolts shall be 2, 3 or 4 (to be stated in the tender).

4.3.4.2. **Connectors (Line Taps)**

4.3.4.2.1. **General**

4.3.4.2.1.1. The connector line taps shall be suitable for use on stranded bare conductors with diameters between 7mm and 15mm and shall correctly fit the conductor it is intended for use.

4.3.4.2.1.2. The connector shall have adequate cross sectional area and dimensions and shall have current carrying capacity at least equal to the capacity of the conductor it is intended for.

4.3.4.2.2. **Aluminium connectors (Aluminium Line Taps).**

4.3.4.2.2.1. Aluminium line taps shall be designed, manufactured and tested in accordance with DIN 48072-1.

4.3.4.2.2.2. Aluminium connectors (line taps) shall be suitable for connecting stranded aluminium conductors of sizes 50mm² and 100mm². The general arrangement of the line taps shall be as per Figure 13 of Annex B.

4.3.4.2.2.3. Line tap body shall be made of electrolytic corrosion resistant, high strength aluminium alloy EN AW-6082 (EN AW-Al Si1MgMn) in accordance BS EN 586-1&2. Chemical composition and mechanical properties shall be submitted for tender evaluation.

4.3.4.2.2.4. The line tap body will be free from porosity and imperfections. The interior surface will be smooth and free from sharp burrs or edges which could damage the conductor. The exterior surface will be smooth.

4.3.4.2.2.5. Bolts shall be made of steel to ISO 898-1, ISO property class 8.8, hot dip galvanized to ISO 1461 with minimum mean coating thickness 40µm. The bolts will be supplied and provided with a thin film of oil.

4.3.4.2.2.6. Pressure pad shall be made of corrosion resistant, aluminium. The thickness of the pad will be such so it will not be twisted after tightening the bolts.

4.3.4.2.2.7. Aluminium line taps shall be as per the general drawing attached in Annex B.

| | |
|---------------------------------------|--|
| Issued by: Head of Section, Standards | Authorized by: Head of Department, Standards |
| Signed: | Signed: |
| Date: 2015-09-17 | Date: 2015-09-17 |



TITLE:
**SPECIFICATION FOR
OVERHEAD LINE FITTINGS
PART 1: FITTINGS FOR 10-
300MM² CONDUCTORS**

| | |
|---------------|----------------------------|
| Doc. No. | KPLC1/6C.1/13/TSP/06/036-1 |
| Issue No. | 2 |
| Revision No. | 1 |
| Date of Issue | 2015-09-17 |
| Page 18 of 45 | |

4.3.4.2.3. Copper connectors (copper line taps)

- 4.3.4.2.3.1. Copper line taps shall be designed, manufactured and tested in accordance with DIN 48072-2 and the general arrangement of the line taps shall be as per Figure 14 of Annex B.
- 4.3.4.2.3.2. Copper connectors shall be suitable for connecting stranded copper conductors of sizes 10 – 70mm².
- 4.3.4.2.3.3. The connector shall be manufactured from high strength cast copper alloy (high copper content) with tinned finish. All copper components or parts shall be made of more than 70% copper content alloy.

4.3.4.2.4. Bi-metal connectors (Bi-metal Line Taps)

- 4.3.4.2.4.1. Bi-metal connectors shall be designed, manufactured and tested in accordance with DIN 48072-1 & 2 and the general arrangement of the line taps shall be as per Figure 14 of Annex B.
- 4.3.4.2.4.2. Bi-metal connectors shall be suitable for connecting stranded aluminium conductors of sizes 50mm² and 100mm² to stranded copper conductors of sizes 10 – 70mm². They shall be manufactured in accordance with DIN 48072-1 & 2 and the general arrangement of the line taps shall be as per Figure 14 of Annex B.
- 4.3.4.2.4.3. The Bi-metallic Connectors shall have:
 - a) All copper components or parts shall be made of more than 70% copper content alloy.
 - b) The copper and aluminium components shall be effectively fused to prevent deterioration by galvanic action.
- 4.3.4.2.4.4. Line tap body shall be made of corrosion resistant, high strength aluminium alloy designation EN AW-6082 (EN AW-Al Si1MgMn) in accordance BS EN 586-1&2 with compressed bimetallic Al-Cu sheet. Chemical composition and mechanical properties shall be submitted for tender evaluation.
- 4.3.4.2.4.5. After compression, the surface around the bimetallic sheet will be painted by protecting epoxy paint.

Issued by: Head of Section, Standards

Signed:

Date: 2015-09-17

Authorized by: Head of Department, Standards

Signed:

Date: 2015-09-17



TITLE:
**SPECIFICATION FOR
OVERHEAD LINE FITTINGS
PART 1: FITTINGS FOR 10-
300MM² CONDUCTORS**

| | |
|---------------|-----------------------------|
| Doc. No. | KPLC/1/6C.1/13/TSP/06/036-1 |
| Issue No. | 2 |
| Revision No. | 1 |
| Date of Issue | 2015-09-17 |
| Page 19 of 45 | |



- 4.3.4.2.4.6. The line tap body shall be free from porosity and imperfections. The interior surface will be smooth and free from sharp burrs or edges which could damage the conductor. The exterior surface will be smooth.
- 4.3.4.2.4.7. Bolts, nuts, washers and other components shall be as per clause 4.2.5 and 4.2.6.

4.4. FINISH AND WORKMANSHIP

- 4.4.1. High quality workmanship shall be maintained in the manufacture of Bolted Clamps and Connectors and shall be free from sharp edges burrs and swarf.
- 4.4.2. The internal faces of aluminium fittings shall be coated with Oxide Inhibiting Grease/Compound to improve electrical contact and ensure maximum electrical performance of fittings. The quantity of Oxide inhibiting grease/compound shall be sufficient to ensure the integrity of the fitting when used on smallest conductor for which it is designed.
- 4.4.3. The Oxide inhibiting grease/compound shall contain suspended particles to penetrate the oxide film present on aluminium surfaces. Full details of the type of Oxide inhibiting grease / compound used in the aluminium components, and document in proof of tests carried out for compatibility shall be furnished for tender evaluation.

4.5. QUALITY MANAGEMENT SYSTEM

- 4.5.1. The supplier shall submit a quality assurance plan (QAP) that will be used to ensure that the cable ties physical, tests and documentations, will fulfill the requirements stated in the contract documents, standards, specifications and regulations. The QAP shall be based on and include relevant parts to fulfill the requirements of ISO 9001:2008.
- 4.5.2. The Manufacturer's Declaration of Conformity to applicable standards and copies of quality management certifications including copy of valid and relevant ISO 9001: 2008 certificate shall be submitted with the tender for evaluation.
- 4.5.3. The bidder shall indicate the delivery time of the items, manufacturer's monthly & annual production capacity and experience in the production of the type and size of items being offered. A detailed list & contact addresses (including e-mail) of the manufacturer's previous customers for similar type of the overhead line fittings sold in the last five years as well as reference letters from at least four of the customers shall be submitted with the tender for evaluation.

| | |
|---|---|
| Issued by: Head of Section, Standards | Authorized by: Head of Department, Standards |
| Signed:  | Signed:  |
| Date: 2015-09-17 | Date: 2015-09-17 |



TITLE:
**SPECIFICATION FOR
OVERHEAD LINE FITTINGS
PART 1: FITTINGS FOR 10-
300MM² CONDUCTORS**

| | |
|---------------|----------------------------|
| Doc. No. | KPLC1/6C.1/13/TSP/06/036-1 |
| Issue No. | 2 |
| Revision No. | 1 |
| Date of Issue | 2015-09-17 |
| Page 20 of 45 | |

5. TESTS AND INSPECTION

- 5.1. The overhead line fittings shall be inspected and tested in accordance with the requirement of IEC 61284, BS 3288, ISO 1461 and this specification. It shall be the responsibility of the manufacturer to perform or to have performed all the tests specified.
- 5.2. Copies of previous Type Test Reports issued by an independent and ISO/IEC 17025 accredited testing laboratory shall be submitted with the tender for the purpose of technical evaluation, all in English language.

Copies of Test Reports (to IEC 61284, BS 3288-1) to be submitted shall include the results of the appropriate type tests made on not less than three fittings identical in all essential details with those to be supplied; and shall include the following:

- (i) Mechanical Type Tests
- (ii) Electrical Type Tests (Resistance and Electrical Heating Cycle Test)
- (iii) Galvanizing Test of the Bolts

- 5.3. The items shall be subject to acceptance tests at the manufacturer's works before dispatch. Acceptance tests shall be witnessed by two Engineers appointed by KPLC.
- 5.4. Complete Test Reports for Sample & Routine Tests to IEC 61284 and BS 3288 for the items shall be submitted to The Kenya Power and Lighting Company for approval before shipment and delivery.

The test reports shall include:



- (i) Verification of Dimensions
- (ii) Mechanical Type Tests
- (iii) Electrical Type Tests (Resistance and Electrical Heating Cycle Test)
- (iv) Galvanizing Test of the Bolts

- 5.5. On receipt of the conductor fittings/accessories, KPLC will inspect them and may perform or have performed any of the relevant tests in order to verify compliance with the specification. The supplier shall replace/rectify without charge to KPLC, items which upon examination, test or use fail to meet any or all of the requirements in the specification.

6. MARKING AND PACKING

6.1. MARKING.

- 6.1.1. Each item shall be marked (during manufacture) legibly and indelibly with the following information.

| | |
|---|---|
| Issued by: Head of Section, Standards | Authorized by: Head of Department, Standards |
| Signed:  | Signed:  |
| Date: 2015-09-17 | Date: 2015-09-17 |



TITLE:
**SPECIFICATION FOR
OVERHEAD LINE FITTINGS
PART 1: FITTINGS FOR 10-
300MM² CONDUCTORS**

| | |
|---------------|----------------------------|
| Doc. No. | KPLC1/6C.1/13/TSP/06/036-1 |
| Issue No. | 2 |
| Revision No. | 1 |
| Date of Issue | 2015-09-17 |
| Page 21 of 45 | |

- a) Manufacturer's identity
- b) Type reference number
- c) Applicable conductor sizes (mm²)
- d) "KPLC"

6.1.2. Instructions for installation and details on applicable tools shall be included in each package, all in English Language.

6.1.3. Conductor fitting shall be identified with the manufacturer's identification marks and fitting references. This marking shall also be applied to any component of the fitting where the component is separate from the fitting when dispatched by the manufacturer.

6.1.4. The following information shall be engraved or embossed outside of all fittings. The conductor type (AAC, ACSR or Copper) size or size range of the conductor for which the fittings are suitable.

6.2. PACKING

6.2.1. Each item shall be suitably sealed in polythene bag to provide mechanical and corrosion protection to contact surfaces in transit and storage. Fifty numbers of same item shall be packed in cardboard box and the box shall be marked with the following information;

- a) Name of item & Batch No.
- b) Code No. as per manufacturers' catalogue
- c) Applicable conductor size
- d) Quantity
- e) Name of manufacturer/Country of manufacture
- f) Year of manufacture
- g) Standard applicable



6.2.2. Packaging shall be such as to permit easy identification of fittings without their removal.

6.2.3. Components of fittings which are not subject to factory assembly shall be secured and packed together as complete fittings, before dispatch.

7. DOCUMENTATION

7.1. The bidder shall submit its tender complete with technical documents required by Annex A (Guaranteed Technical Particulars) for tender evaluation. The technical documents to be submitted (all in English language) for tender evaluation shall include the following:

- a) Guaranteed Technical Particulars fully filled and signed by the manufacturer;

| | |
|---|---|
| Issued by: Head of Section, Standards | Authorized by: Head of Department, Standards |
| Signed:  | Signed:  |
| Date: 2015-09-17 | Date: 2015-09-17 |



TITLE:
**SPECIFICATION FOR
OVERHEAD LINE FITTINGS
PART 1: FITTINGS FOR 10-
300MM² CONDUCTORS**

| | |
|---------------|----------------------------|
| Doc. No. | KPLC1/6C.1/13/TSP/06/036-1 |
| Issue No. | 2 |
| Revision No. | 1 |
| Date of Issue | 2015-09-17 |
| Page 22 of 45 | |

- b) Copies of the Manufacturer's catalogues, brochures, drawings and technical data of each overhead line fittings on tender;
- c) Sales records and customer reference letters;
- d) Details of manufacturing capacity and the manufacturer's experience;
- e) Copies of required type test reports by a third party testing laboratory accredited to ISO/IEC 17025;
- f) Copy of accreditation certificate to ISO/IEC 17025 for the testing laboratory.
- g) Manufacturer's warranty and guarantee
- h) Manufacturer's letter of authorization, copy of the manufacturer's ISO 9001:2008/ KEBS Diamond mark certificate and other technical documents required in the tender.
- i) The following **SHALL** be supplied with the offer.
 - (i) Constructional features, material used for components and relevant technical literature in English.
 - (ii) All the dimensions of the fitting (inside & outside), and drawings shall be furnished.
 - (iii) The current carrying capacity, Temperature rise and other relevant technical details shall also be furnished.
 - (iv) The standard to which the fittings are manufactured shall also be mentioned.
 - (v) Full details of the type of Oxide inhibiting grease/compound used and documents in proof of tests carried out for compatibility with the conductor material.
 - (vi) Documentary evidence to prove ISO 9002 Certification for Bi-metallic Clamps and connectors.

7.2. The successful bidder (supplier) shall submit the following documents/details to The Kenya Power & Lighting Company for approval before manufacture:

- a) Guaranteed Technical Particulars signed by the manufacturer;
- b) Design Drawings with details of each overhead line fittings to be manufactured for KPLC.
- c) Quality assurance plan (QAP) that will be used to ensure that the design, material; workmanship, tests, service capability, maintenance and documentation will fulfil the requirements stated in the contract documents, standards, specifications and regulations. The QAP shall be based on and include relevant parts to fulfil the requirements of ISO 9001:2008
- d) Detailed test program to be used during factory testing;
- e) Marking details and method to be used in marking the each overhead line fittings;
- f) Manufacturer's undertaking to ensure adequacy of the design, good engineering practice, adherence to the specification and applicable standards and regulations as well as ensuring good workmanship in the manufacture of the overhead line fittings for The Kenya Power & Lighting Company;
- g) Packaging details (including packaging materials).

Issued by: Head of Section, Standards

Authorized by: Head of Department, Standards

Signed:

Signed:

Date: 2015-09-17

Date: 2015-09-17





TITLE:
**SPECIFICATION FOR
OVERHEAD LINE FITTINGS
PART 1: FITTINGS FOR 10-
300MM² CONDUCTORS**

| | |
|---------------|----------------------------|
| Doc. No. | KPLC1/6C.1/13/TSP/06/036-1 |
| Issue No. | 2 |
| Revision No. | 1 |
| Date of Issue | 2015-09-17 |
| Page 23 of 45 | |

7.3 The supplier shall submit recommendations for use, care, storage and routine inspection/testing procedures, all in the English Language, during delivery of the each overhead line fittings to KPLC store

THIS SPACE LEFT INTENTIONALLY BLANK

| | |
|---|---|
| Issued by: Head of Section, Standards | Authorized by: Head of Department, Standards |
| Signed:  | Signed:  |
| Date: 2015-09-17 | Date: 2015-09-17 |



TITLE:
**SPECIFICATION FOR
 OVERHEAD LINE FITTINGS
 PART 1: FITTINGS FOR 10-
 300MM² CONDUCTORS**

| | |
|---------------|----------------------------|
| Doc. No. | KPLC1/6C.1/13/TSP/06/036-1 |
| Issue No. | 2 |
| Revision No. | 1 |
| Date of Issue | 2015-09-17 |
| Page 24 of 45 | |

ANNEX A: Guaranteed Technical Particulars (to be filled and signed by the Manufacturer and submitted together with copies of manufacturer's catalogues, brochures, drawings, technical data, sales records, customer reference letters, details of manufacturing capacity & experience and copies of type test reports for tender evaluation)

Tender No.

| Clause number | KPLC Requirements | Bidder's offer (indicate full details) | | |
|-------------------------|--|--|-----------------------|-------|
| 4.3.1 | Conductor terminations | | | |
| 4.3.1.1 | Ball Ended Hook, Ball Clevis, Socket Clevis and Socket Tongue | | | |
| | Ball Ended Hook | | | |
| | Manufacturer and country of manufacture | State | | |
| | Standards of manufacture | State | | |
| | Reference Number as per BS 3288 | State | | |
| | Dimensional requirements as per BS 3288-2 | Attach a drawing | | |
| Design and construction | Free from defects, sharp edges and swarfs | State | | |
| | Corrosion resistant | State | | |
| | Material of manufacture | State | | |
| | Bolts & nuts | Material and standard of manufacture | State | |
| | | Threading | Mechanical properties | State |
| | | | Process | State |
| | | | Design | State |
| | Tolerance | | State | |
| | Washers | Material of manufacture | State | |
| | | Mechanical properties | State | |
| | | Surface hardness | State | |
| | Locking devices | Split pins | Attach drawing | |
| | | Security clip | Attach drawing | |
| | Manufacturing process | State | | |
| | Material manufacture | Steel designation | Attach test report | |
| Standard of manufacture | | | | |
| Chemical composition | | Sulphur | | |
| | | Phosphorous | | |
| | | Nickel | | |
| | | Chromium | | |
| | | Molybdenum | | |
| Others | | | | |
| Tempering temperature | | | | |
| Surface hardness | | | | |
| | Ball clevis | | | |
| | Manufacturer and country of manufacture | State | | |
| | Standards of manufacture | State | | |
| | Reference Number as per BS 3288 | State | | |
| | Dimensional requirements as per BS 3288-2 | Attach a drawing | | |
| Design and construction | Free from defects, sharp edges and swarfs | State | | |
| | Corrosion resistant | State | | |

Issued by: Head of Section, Standards

Authorized by: Head of Department, Standards

Signed:

Signed:

Date: 2015-09-17

Date: 2015-09-17



TITLE:
**SPECIFICATION FOR
OVERHEAD LINE FITTINGS
PART 1: FITTINGS FOR 10-
300MM² CONDUCTORS**

| | |
|----------------------|----------------------------|
| Doc. No. | KPLC1/6C.1/13/TSP/06/036-1 |
| Issue No. | 2 |
| Revision No. | 1 |
| Date of Issue | 2015-09-17 |
| Page 25 of 45 | |

| | | | | | | |
|-----------------------|--|-------------------------|--------------------------------------|-----------------------|--------------------|-------|
| | | Material of manufacture | | State | | |
| | | Bolts & nuts | Material and standard of manufacture | | State | |
| | | | Threading | Mechanical properties | | State |
| | | | | Process | | State |
| | | | | Design | | State |
| | | | | Tolerance | | State |
| | | Washers | Material of manufacture | | State | |
| | | | Mechanical properties | | State | |
| | | | Surface hardness | | State | |
| | | Locking devices | Split pins | | Attach drawing | |
| | | | Security clip | | Attach drawing | |
| | | Manufacturing process | | | State | |
| | | Material manufacture | Steel designation | | Attach test report | |
| | | | Standard of manufacture | | | |
| | | | Chemical composition | Sulphur | | |
| Phosphorous | | | | | | |
| Nickel | | | | | | |
| Chromium | | | | | | |
| Molybdenum | | | | | | |
| Others | | | | | | |
| Tempering temperature | | | | | | |
| Surface hardness | | | | | | |

| | | | | | |
|-------------------------|--|--------------------------------------|-----------------------|----------------|-------|
| Design and construction | Socket clevis, single and double hole | | | | |
| | Manufacturer and country of manufacture | | | State | |
| | Standards of manufacture | | | State | |
| | Reference Number as per BS 3288 | Socket clevis, single hole | | State | |
| | | Socket clevis, double hole | | | |
| | Dimensional requirements as per BS 3288-2 | Socket clevis, single hole | | Attach drawing | |
| | | Socket clevis, double hole | | | |
| | Free from defects, sharp edges and swarfs | | | State | |
| | Corrosion resistant | | | State | |
| | Material of manufacture | | | State | |
| | Bolts & nuts | Material and standard of manufacture | | State | |
| | | Threading | Mechanical properties | | State |
| | | | Process | | State |
| | | | Design | | State |
| | | | Tolerance | | State |
| | Washers | Material of manufacture | | State | |
| | | Mechanical properties | | State | |
| | | Surface hardness | | State | |
| | Locking devices | Split pins | | Attach drawing | |
| | | Security clip | | Attach drawing | |
| Manufacturing process | | | State | | |
| Material manufacture | Standard of manufacture | | Attach test report | | |
| | Steel designation | | | | |
| | Chemical composition | Sulphur | | | |
| | | Phosphorous | | | |
| | | Nickel | | | |
| | | Chromium | | | |
| Molybdenum | | | | | |

| | |
|--|---|
| Issued by: Head of Section, Standards | Authorized by: Head of Department, Standards |
| Signed: | Signed: |
| Date: 2015-09-17 | Date: 2015-09-17 |



TITLE:
SPECIFICATION FOR OVERHEAD LINE FITTINGS PART 1: FITTINGS FOR 10-300MM² CONDUCTORS

| | |
|---------------|----------------------------|
| Doc. No. | KPLC1/6C.1/13/TSP/06/036-1 |
| Issue No. | 2 |
| Revision No. | 1 |
| Date of Issue | 2015-09-17 |
| Page 26 of 45 | |

| | | | | | |
|-------------------------|--|--|-----------------------|--------------------|--|
| | | | Others | | |
| | | | Tempering temperature | | |
| | | | Surface hardness | | |
| | Socket tongue, single and Double hole | | | | |
| | Manufacturer and country of manufacture | | | State | |
| | Standards of manufacture | | | State | |
| | Reference Number as per BS 3288 | Socket tongue, single hole Socket tongue, double hole | | State | |
| | Dimensional requirements as per BS 3288-2 | Socket tongue, single hole Socket tongue, double hole | | Attach drawing | |
| Design and construction | Free from defects, sharp edges and swarfs | | | State | |
| | Corrosion resistant | | | State | |
| | Material of manufacture | | | State | |
| | Bolts & nuts | Material and standard of manufacture | | State | |
| | | Threading | Mechanical properties | State | |
| | | | Process | State | |
| | | | Design | State | |
| | Locking devices | Split pins | | Attach drawing | |
| | | Security clip | | Attach drawing | |
| | Manufacturing process | | | State | |
| | Material manufacture | Steel designation | | Attach test report | |
| | | Standard of manufacture | | | |
| | | Chemical composition | Sulphur | | |
| | | | Phosphorous | | |
| Nickel | | | | | |
| Chromium | | | | | |
| Molybdenum | | | | | |
| Others | | | | | |
| Surface hardness | | | | | |
| Tempering temperature | | | | | |
| 4.3.2 | Tension Clamp (Strain Clamp) | | | State | |
| | Bidders name and address | | | State | |
| | Manufacturer and country of manufacture | | | State | |
| | Type designation or catalogue number | | | State | |
| | Standard of manufacture | | | State | |
| | Scope – sizes of conductors applicable | | | State | |
| | Type of tension clamp – No. of bolts | | | State | |
| | Slip strength | | | State | |
| Material of manufacture | Body and keeper | Type of aluminium alloy | | Attach test report | |
| | | Grade or designation | | | |
| | | Standard of manufacture | | | |
| | | % Cu content | | | |
| | | Inter-crystalline resistant alloy | | | |
| | | Brinell Hardness | | | |
| | | Resistivity at 20 ^o C, nΩ | | | |
| | | Proof stress, MPa | | | |
| Tensile strength, MPa | | Declare | | | |

Issued by: Head of Section, Standards

Authorized by: Head of Department, Standards

Signed:

Signed:

Date: 2015-09-17

Date: 2015-09-17





TITLE:
**SPECIFICATION FOR
OVERHEAD LINE FITTINGS
PART 1: FITTINGS FOR 10-
300MM² CONDUCTORS**

| | |
|---------------|-----------------------------|
| Doc. No. | KPLC/1/6C.1/13/TSP/06/036-1 |
| Issue No. | 2 |
| Revision No. | 1 |
| Date of Issue | 2015-09-17 |
| Page 27 of 45 | |

| | | | | |
|--|--|--|--|--|
| | | Thread inserts | A ₅₀ % elongation | guaranteed values and Attach test report |
| | | | Type of steel | |
| | | | Standard of manufacture | |
| | | | Grade or designation | |
| | | | Corrosion resistant | |
| | | | Mechanical properties | |
| | | Straps | Type of steel | |
| | | | Zinc coating thickness (average) | |
| | | Bolts and nuts | Type of steel | |
| | | | Standard of manufacture | |
| | | | Grade or designation | |
| | | | Corrosion resistant | |
| | | | Mechanical properties as per ISO 898-1 & 2 | |
| | Washers | Type of steel | | |
| | | Standard of manufacture | | |
| | | Grade or designation | | |
| | | Corrosion resistant | | |
| | | | Surface hardness - HBW | |
| | Design | Clamp | Conductor shall be able to move along the clamp | |
| | | | Trunnion shall be part of the clamp | |
| Conductor supporting groove | | Profile shall be as per Fig 7 of tender specification | | |
| | | Groove radii in body and keeper shall be adjustable to fit conductor closely | | |
| | | Groove free from irregularities and sharp edges | | |
| Clamps shall be free from fatigue damages | | | | |
| Straps | | Hole in strap and trunnion body shall be round | | |
| | | Size of hole shall match trunnion | | |
| Bolts and nuts | Shall be with metric threads as per ISO 272 | | | |
| | Bolts shall be attached so avoid accidental drop | | | |
| | Provision to tighten from upper part of clamp | | | |
| | Long bolts to protrude outside the nut | | | |
| Washers | Counter bores and countersink as per DIN 74-1 | | | |
| | Shall be as per ISO 7091 | | | |
| 4.3.3 | Suspension clamps | | | |
| Bidders name and address | | | State | |
| Manufacturer and country of manufacture | | | State | |
| Type designation or catalogue number | | | State | |
| Standard of manufacture | | | State | |
| Scope – sizes of conductors applicable | | | State | |
| Type of tension clamp | Pivot or Trunion type | Keeper type with U-Clamps | | |
| | | Closed Type | | |
| Envelop type | Clevis ended hook type | | | |
| | Tongue ended hook type | | | |
| Applicable for both phase and shield wires for both straight and angle lines | | | Declare guaranteed values and Attach test report | |
| Material of manufacture | Body and keeper | Type of aluminium alloy | | |
| | | Grade or designation | | |
| | | Standard of manufacture | | |

| | |
|---------------------------------------|--|
| Issued by: Head of Section, Standards | Authorized by: Head of Department, Standards |
| Signed: | Signed: |
| Date: 2015-09-17 | Date: 2015-09-17 |

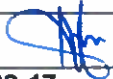
| | | | | |
|---------|---|---|--|--|
| | | | % Cu content | |
| | | | Inter-crystalline resistant alloy | |
| | | | Brinell Hardness | |
| | | | Resistivity at 20 ^o C, nΩ | |
| | | | Proof stress, MPa | |
| | | | Tensile strength, MPa | |
| | | | A ₅₀ % elongation | |
| | | Thread inserts | Type of steel | |
| | | | Standard of manufacture | |
| | | | Grade or designation | |
| | | | Corrosion resistant | |
| | | Straps | Type of steel | |
| | | | Zinc coating thickness (average) | |
| | | Bolts and nuts | Type of steel | |
| | | | Standard of manufacture | |
| | | | Grade or designation | |
| | | | Corrosion resistant | |
| | | Washers | Mechanical properties as per ISO 898-1 & 2 | |
| | | | Type of steel | |
| | | | Standard of manufacture | |
| | | | Grade or designation | |
| | | | Corrosion resistant | |
| | | | Surface hardness - HBW | |
| | Design | General design is as per drawing in Fug. 8 & 9 in annex B | | Attach drawing |
| | | Clamp | Conductor shall be able to move along the clamp | Declare guaranteed values and Attach test report |
| | | | Trunnion shall be part of the clamp | |
| | | | Profile shall be as per Fig 7 of tender specification | |
| | | Conductor supporting groove | Groove radii in body and keeper shall be adjustable to fit conductor closely | |
| | | | Groove free from irregularities and sharp edges | |
| | | Clamps shall be free from fatigue damages | | |
| | | Bolts and nuts | Hole in strap and trunnion body shall be round | |
| | | | Size of hole shall match trunnion | |
| | | | Shall be with metric threads as per ISO 272 | |
| | Bolts shall be attached so avoid accidental drop | | | |
| | Provision to tighten from upper part of clamp | | | |
| | | Long bolts to protrude outside the nut | | |
| | | Counter bores and countersink as per DIN 74-1 | | |
| | Washers | Shall be as per ISO 7091 | | |
| 4.3.4 | Non Tension (Bolted) Connectors | | | |
| 4.3.4.1 | Parallel Groove Clamp (PG Clamp) | | | |
| | Bidders name and address | | | State |
| | Manufacturers name and country of manufacture | | | State |
| | Standard of manufacture | | | State |
| | Type designation or catalogue number | | | State |
| | Scope of use and Sizes of cable applicable | | | State |
| | Electrical power rating – short circuit current, kA/s | | | State |
| | Material | Aluminium Alloy Castings / Forgings / Extrusions | | Declare |

| | |
|---|---|
| Issued by: Head of Section, Standards | Authorized by: Head of Department, Standards |
| Signed:  | Signed:  |
| Date: 2015-09-17 | Date: 2015-09-17 |



TITLE:
SPECIFICATION FOR OVERHEAD LINE FITTINGS PART 1: FITTINGS FOR 10-300MM² CONDUCTORS

| | |
|----------------------|-----------------------------|
| Doc. No. | KPLC/1/6C.1/13/TSP/06/036-1 |
| Issue No. | 2 |
| Revision No. | 1 |
| Date of Issue | 2015-09-17 |
| Page 29 of 45 | |

| | | | | | | |
|-----------|---|--|---|--|---|---|
| | | Body | Type of aluminium alloy Grade or designation Standard of manufacture % Cu content Inter-crystalline resistant alloy Brinell Hardness Resistivity at 20 ^o C, nΩ Proof stress, MPa Tensile strength, MPa A ₅₀ % elongation | guaranteed values and Attach test report | | |
| | | Inserts | Type of steel Standard of manufacture Grade or designation Corrosion resistant Mechanical properties | | | |
| | | | Straps | | Type of steel Zinc coating thickness (average) | |
| | | | | | Bolts and nuts | Type of steel Standard of manufacture Grade or designation Corrosion resistant Mechanical properties as per ISO 898-1 & 2 |
| | | | Washers | | | Type of steel Standard of manufacture Grade or designation Corrosion resistant Surface hardness - HBW |
| Design | General design is as per drawing in Fig. 10, 11 & 12 in annex B | | | | | Attach drawing |
| | Conductor supporting groove | Conductor shall be able to move along the clamp Groove radii in body shall be adjustable to fit conductor closely Groove free from irregularities and sharp edges | | | | Declare guaranteed values and Attach test report |
| | | Clamps shall be free from fatigue damages | | | | |
| | Bolts and nuts | Hole in strap and body shall be round Shall be as per ISO 272 Bolts shall be attached so avoid accidental drop Provision to tighten from upper part of clamp Long bolts to protrude outside the nut Counter bores and countersink as per DIN 74-1 | | | | |
| | | Washers Shall be as per ISO 7091 | | | | |
| 4.3.4.2 | | Connectors(Line Taps) | | | | |
| 4.3.4.2.1 | | General | | | State | |
| 4.3.4.2.2 | Aluminium line taps | | | | | |
| | Manufacturers name and country of manufacture | | | | | |
| | Standard of manufacture | | | | | |
| | Type designation or catalogue number | | | | | |
| | Scope of use and Sizes of cable applicable | | | | | |
| | Electrical power rating – short circuit current, kA/s | | | | | |
| | Material of | Body | Shall be made of electrolytic corrosion resistant, | Declare | | |

| | |
|--|---|
| Issued by: Head of Section, Standards | Authorized by: Head of Department, Standards |
| Signed: | Signed: |
| Date: 2015-09-17 | Date: 2015-09-17 |



TITLE:
SPECIFICATION FOR OVERHEAD LINE FITTINGS PART 1: FITTINGS FOR 10-300MM² CONDUCTORS

| | |
|---------------|-----------------------------|
| Doc. No. | KPLC/1/6C.1/13/TSP/06/036-1 |
| Issue No. | 2 |
| Revision No. | 1 |
| Date of Issue | 2015-09-17 |
| Page 30 of 45 | |

| | | | | | |
|-----------|--|----------------|--|--|---|
| | manufacture | | high strength aluminium alloy | guaranteed values and Attach test report | |
| | | | Type designation of aluminium alloy | | |
| | | | Standard of manufacture | | |
| | | | Chemical composition | | |
| | | | Mechanical properties | | |
| | | | Bolts and nuts | | Type of steel |
| | | | | | Standard of manufacture |
| | | | | | Grade or designation |
| | | | | | Corrosion resistant |
| | | | | | Mechanical properties as per ISO 898-1 &2 |
| Design | General design is as per drawing in Fig. 13 in annex B | | Attach drawing | | |
| 4.3.4.2.3 | Copper line taps | | | | |
| | Bidders name and address | | | State | |
| | Manufacturers name and country of manufacture | | | State | |
| | Standard of manufacture | | | State | |
| | Type designation or catalogue number | | | State | |
| | Scope of use and Sizes of cable applicable | | | State | |
| | Electrical power rating – short circuit current, kA/s | | | State | |
| | Material of manufacture | Body | Shall be made of electrolytic corrosion resistant, high strength aluminium alloy | Declare guaranteed values and Attach test report | |
| | | | Type designation of aluminium alloy | | |
| | | | Standard of manufacture | | |
| | | | Chemical composition | | |
| | | | Mechanical properties | | |
| | | Bolts and nuts | Type of steel | | |
| | | | Standard of manufacture | | |
| | | | Grade or designation | | |
| | | | Corrosion resistant | | |
| | | | Mechanical properties as per ISO 898-1 &2 | | |
| Design | General design is as per drawing in Fig. 14 in annex B | | Attach drawing | | |
| 4.3.4.2.4 | Bimetallic line taps | | | | |
| | Bidders name and address | | | State | |
| | Manufacturers name and country of manufacture | | | State | |
| | Standard of manufacture | | | State | |
| | Type designation or catalogue number | | | State | |
| | Scope of use and Sizes of cable applicable | | | State | |
| | Electrical power rating – short circuit current, kA/s | | | State | |
| | Material of manufacture | Body | Shall be made of electrolytic corrosion resistant, high strength aluminium alloy | Declare guaranteed values and Attach test report | |
| | | | Type designation of aluminium alloy | | |
| | | | Standard of manufacture | | |
| | | | Chemical composition | | |
| | | | Mechanical properties | | |
| | | Bolts and nuts | Type of steel | | |
| | | | Standard of manufacture | | |
| | | | Grade or designation | | |
| | | | Corrosion resistant | | |
| | | | Mechanical properties as per ISO 898-1 &2 | | |
| Design | General design is as per drawing in Fig. 13 in annex B | | Attach drawing | | |

| | |
|--|---|
| Issued by: Head of Section, Standards | Authorized by: Head of Department, Standards |
| Signed: | Signed: |
| Date: 2015-09-17 | Date: 2015-09-17 |



TITLE:
**SPECIFICATION FOR
 OVERHEAD LINE FITTINGS
 PART 1: FITTINGS FOR 10-
 300MM² CONDUCTORS**

| | |
|---------------|----------------------------|
| Doc. No. | KPLC1/6C.1/13/TSP/06/036-1 |
| Issue No. | 2 |
| Revision No. | 1 |
| Date of Issue | 2015-09-17 |
| Page 31 of 45 | |

| | | |
|------|---|---------|
| 4.4 | Finish and Workmanship | Declare |
| 4.5 | Quality Management System | State |
| | Quality Assurance Plan | State |
| | Copy of ISO 9001:2008 Certificate | State |
| | Manufacturer's experience | State |
| | Manufacturing Capacity (units per month) | State |
| | List of previous customers | State |
| | Customer reference letters | State |
| 5.1 | Test standards and responsibility of carrying out tests | provide |
| 5.2 | Copies of Type Test Reports submitted with tender | provide |
| 5.3 | Acceptance tests to be witnessed by KPLC at factory before shipment | provide |
| 5.4 | Test reports to be submitted by supplier to KPLC for approval before shipment | provide |
| 5.5 | Replacement of rejected overhead line fittings | provide |
| 6.1 | Marking | provide |
| 6.2 | Packing | provide |
| 7.1 | Documents submitted with tender | provide |
| 7.2 | Documents to be submitted by supplier to KPLC for approval before manufacture | provide |
| 8.0 | Manufacturer's Guarantee and Warranty | provide |
| 9.0 | List catalogues, brochures, technical data and drawings submitted to support the offer | provide |
| 10.0 | List customer sales records and reference letters submitted to support the offer | provide |
| 11.0 | List Test Certificates submitted with tender | provide |
| 12.0 | List test reports of the surge arresters to be submitted to KPLC for approval before shipment | provide |
| 13.0 | Statement of compliance to specification (indicate deviations if any & supporting documents) | provide |

NOTE:

- 1) *Bidders shall give full details of the offered values for the items on order as per Annex A. The details provided shall conform to the test reports and their certificates as required by clause 5.2., well labeled drawings complete with dimensions, catalogues and/or brochures for the purpose of tender evaluation. Bidders who shall have not complied by this requirement shall be automatically disqualified from bidding this item.*
- 2) *The schedule in Annex A does not in any way substitute for detailed information required elsewhere in the specification.*

.....
Manufacturer's Name, Signature, Stamp and Date

| | |
|---------------------------------------|--|
| Issued by: Head of Section, Standards | Authorized by: Head of Department, Standards |
| Signed: | Signed: |
| Date: 2015-09-17 | Date: 2015-09-17 |

ANNEX B: General Arrangement Drawings (ATTACHED)

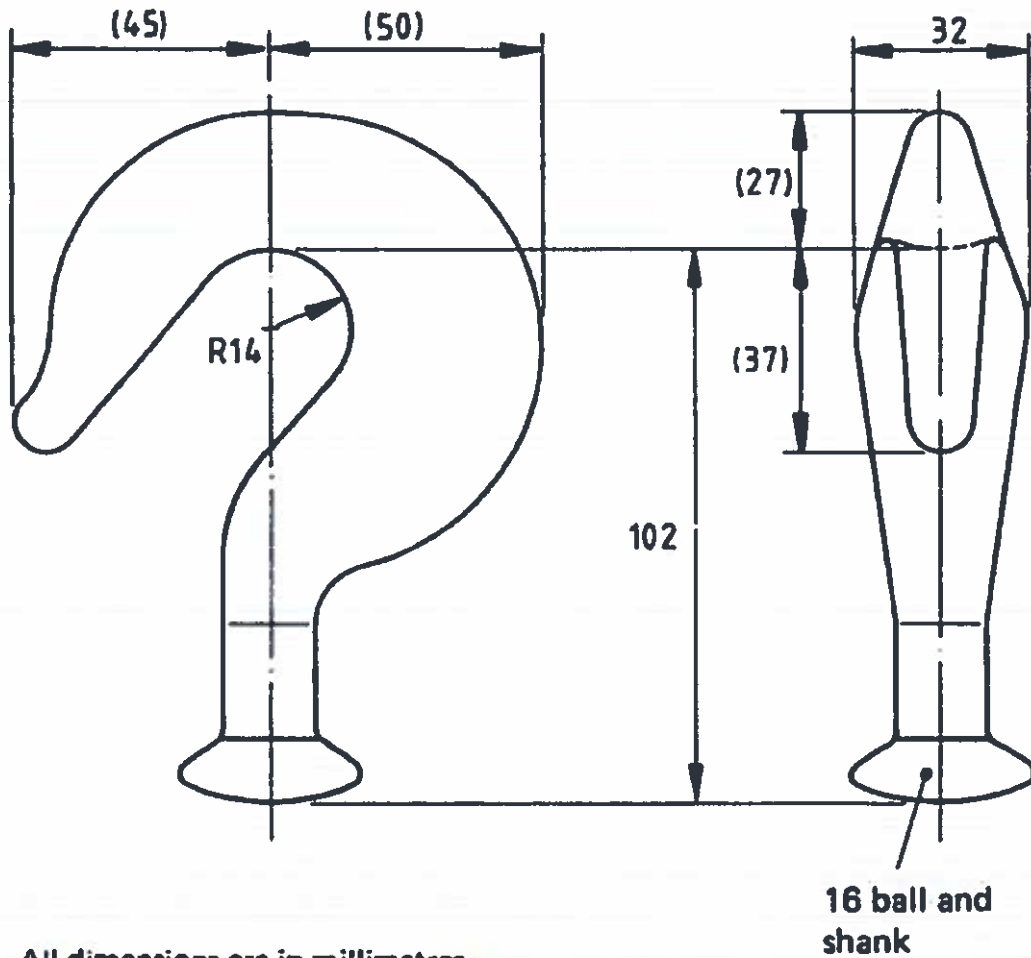

All dimensions are in millimetres.

Figure 1: Ball-ended hook: reference number 15/81 (minimum failing load – 70kN)

| | |
|---|---|
| Issued by: Head of Section, Standards | Authorized by: Head of Department, Standards |
| Signed:  | Signed:  |
| Date: 2015-09-17 | Date: 2015-09-17 |

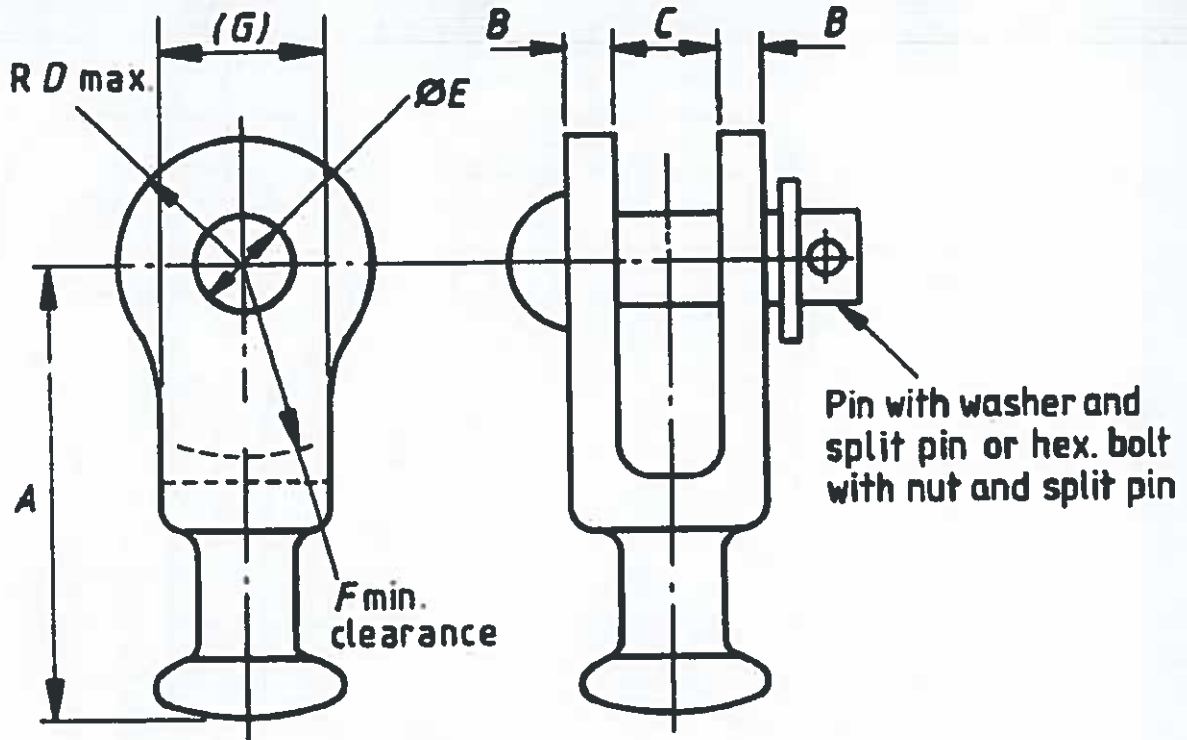



NOTE. Pin, split pin and washer (or bolt, nut and split pin) are included.

Table 1: Dimensions of ball and clevis: Reference number 15/83 as per BS 3288-2

| Reference number | Minimum failing load kN | Ball size | A mm | B mm | C mm | D mm | ϕE mm | F mm | Pin | | Bolt | |
|------------------|----------------------------|-----------|---------|---------|---------|---------|----------------|---------|----------------|--------------|----------------|--------------|
| | | | | | | | | | Diameter mm | Length mm | Diameter mm | Length mm |
| 15/83 | 70 | 16 | 89 | 8 | 18.5 | 23 | 18 | 32 | 16 | 50 | M16 | 65 |

Figure 2: Ball clevis: Reference number 15/83 as per BS 3288-2

| | |
|---|---|
| Issued by: Head of Section, Standards | Authorized by: Head of Department, Standards |
| Signed:  | Signed:  |
| Date: 2015-09-17 | Date: 2015-09-17 |

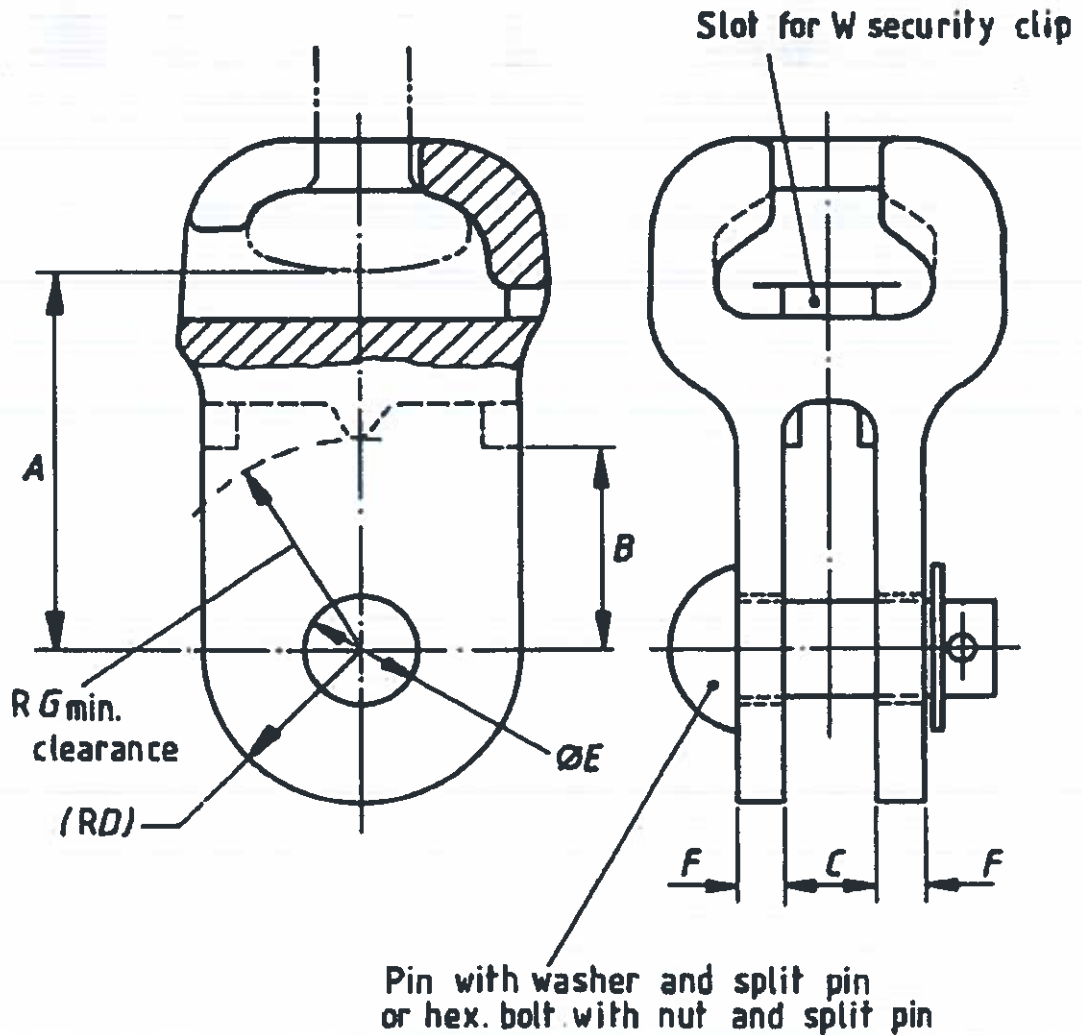

NOTE. Security clip, pin, split pin and washer (or bolt, nut and split pin) are included.

Table 2: Dimensions of socket clevis: Reference number 15/84 as per BS 3288-2

| Reference number | Minimum failing load kN | Socket size | A | B | C | D | φ E | F | G | Pin | | Bolt | |
|------------------|----------------------------|-------------|-----|----|------|----|-----|----|----|----------|--------|----------|--------|
| | | | mm | mm | mm | mm | | mm | mm | Diameter | Length | Diameter | Length |
| 15/83 | 70 | 16 | 168 | 59 | 18.5 | 23 | 18 | 8 | 38 | 16 | 50 | M16 | 65 |

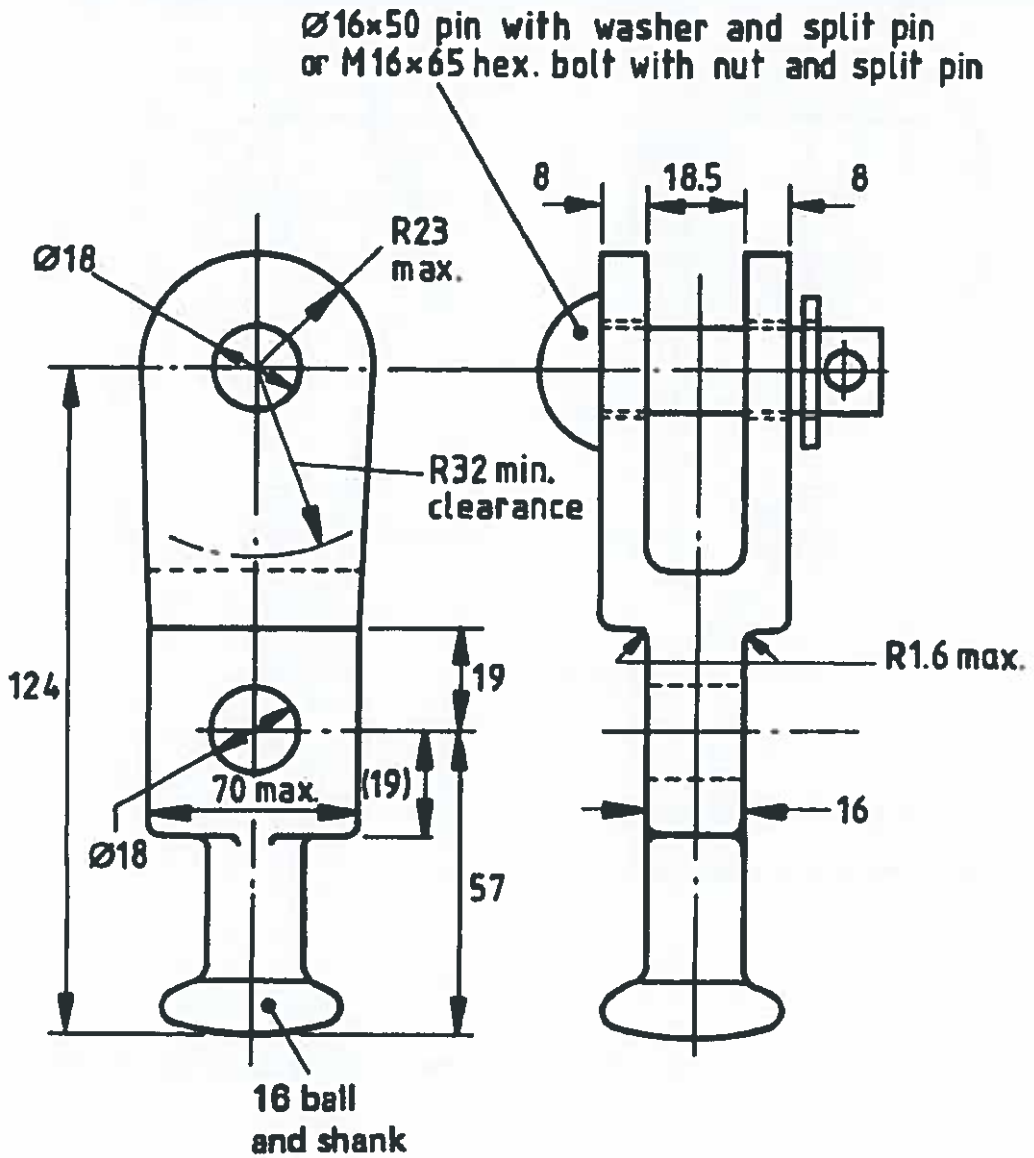

Figure 3: Socket clevis, single hole: Reference number 15/84 as per BS 3288-2

| | |
|---|---|
| Issued by: Head of Section, Standards | Authorized by: Head of Department, Standards |
| Signed:  | Signed:  |
| Date: 2015-09-17 | Date: 2015-09-17 |



All dimensions are in millimetres.

Figure 4: Sock clevis, double hole: reference number 15/25 (minimum failing load -- 70kN)

| | |
|---|---|
| Issued by: Head of Section, Standards | Authorized by: Head of Department, Standards |
| Signed:  | Signed:  |
| Date: 2015-09-17 | Date: 2015-09-17 |

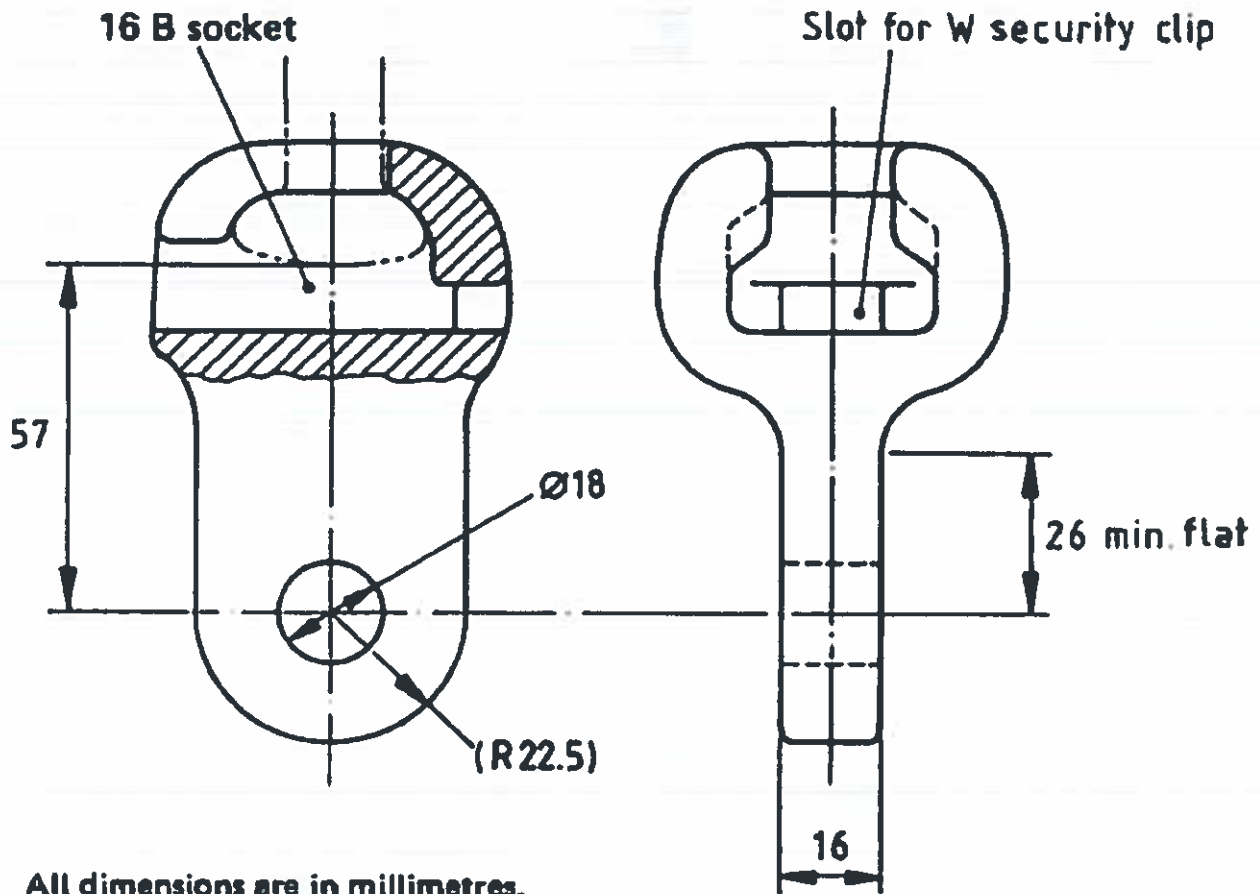

All dimensions are in millimetres.

NOTE. Security clip is included.

Figure 5: Socket tongue, single hole: reference number 15/85 (minimum failing load – 70kN)

Issued by: Head of Section, Standards

Signed:



Date: 2015-09-17

Authorized by: Head of Department, Standards

Signed:



Date: 2015-09-17

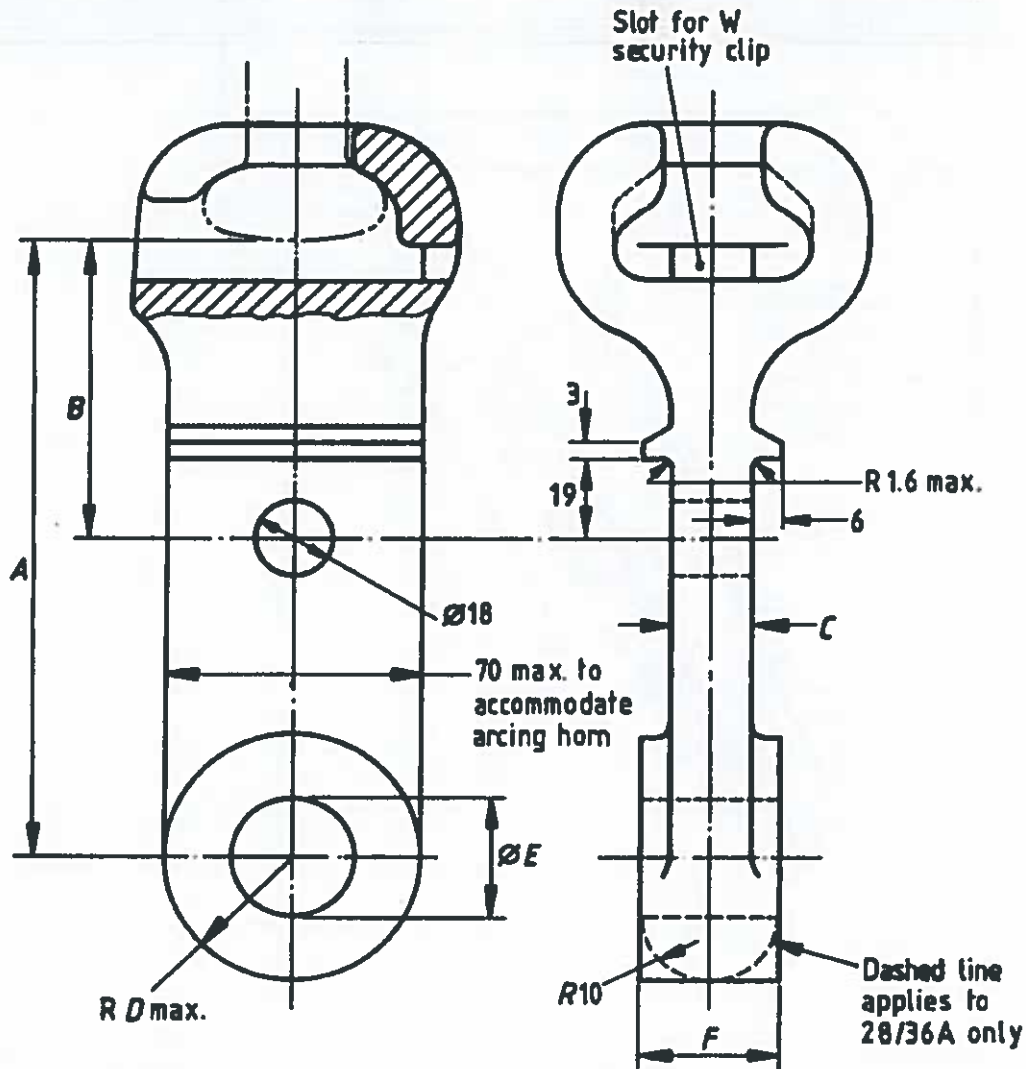



All dimensions are in millimetres.
 NOTE. Security clip is included.

Table 3: Dimensions of socket tongue: Reference number 15/35 as per BS 3288-2

| Reference number | Minimum failing load | Ball size | A | B | C | D max | ΦE | F |
|------------------|----------------------|-----------|-----|----|----|-------|----|----|
| | kN | | mm | mm | mm | mm | mm | mm |
| 15/35 | 70 | 16B | 130 | 86 | 16 | 23 | 18 | 16 |

Figure 6: Socket tongue, double hole: reference number 15/85 (minimum failing load – 70kN)

| | |
|---|---|
| Issued by: Head of Section, Standards | Authorized by: Head of Department, Standards |
| Signed:  | Signed:  |
| Date: 2015-09-17 | Date: 2015-09-17 |

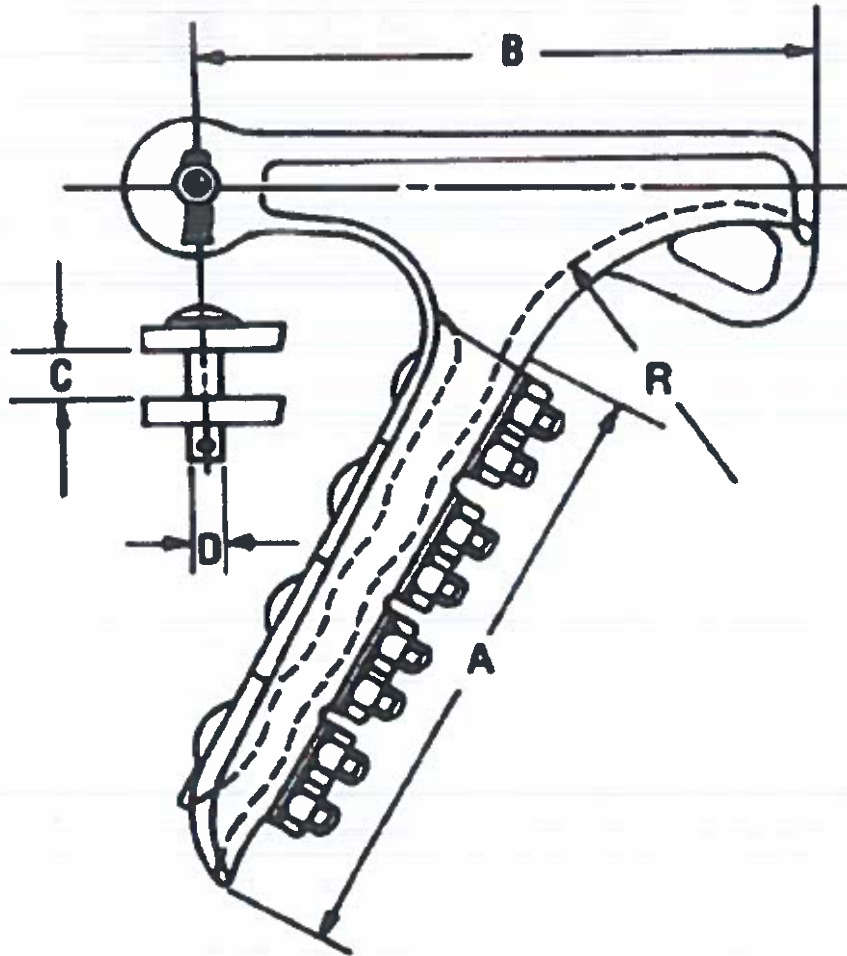

| Designation | Conductor Range (mm) | | Dimensions (mm) | | | | | U-Bolt | | Ultimate Strength Kgs |
|-------------|----------------------|------|-----------------|-----|------|------|-----|--------|------|-----------------------|
| | Max | Min | A | B | C | D | R | No | Size | |
| A | 5.1 | 12.5 | 187 | 203 | 17.4 | 16 | 95 | 3 | M12 | 6,810 |
| B | 12.4 | 18.3 | 225 | 221 | 20.6 | 16 | 121 | 4 | M12 | 9,090 |
| C | 18 | 30.5 | 400 | 350 | 35 | 25.4 | 187 | 5 | M16 | 13,600 |

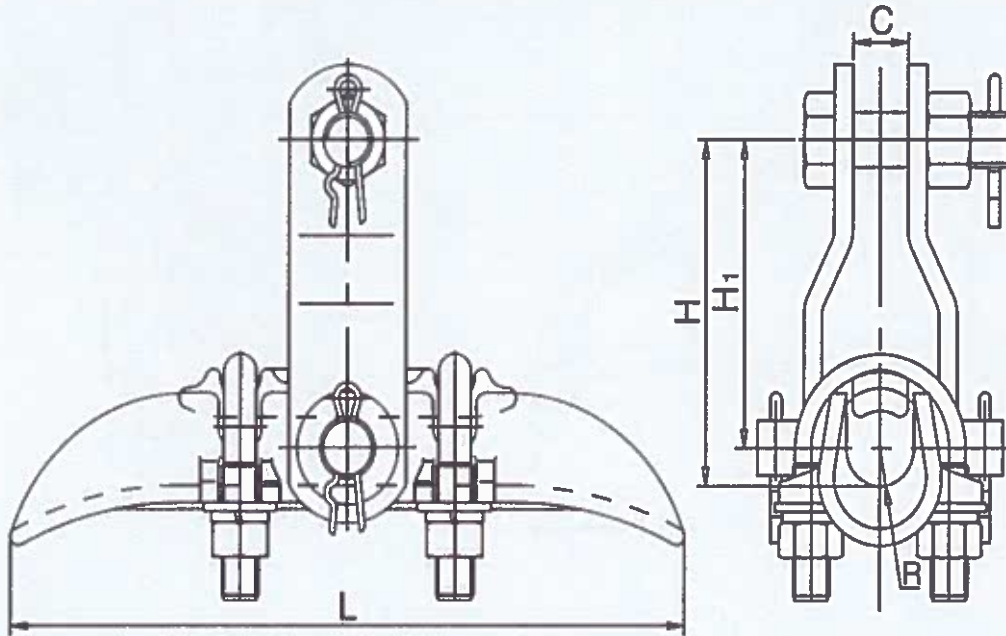

Figure 7: Bolted Tension (Strain) Clamp

| | |
|---|---|
| Issued by: Head of Section, Standards | Authorized by: Head of Department, Standards |
| Signed:  | Signed:  |
| Date: 2015-09-17 | Date: 2015-09-17 |



| Conductor Diameter (mm) | Dimensions (mm) | | | | | Rated Failure Load (kN) | Approximate weight Kg |
|----------------------------|-----------------|-----|-----|------|----|-------------------------|--------------------------|
| | H | H1 | L | R | C | | |
| 5.0~6.0 | 82 | 70 | 180 | 4.0 | 18 | 40 | 1.4 |
| 7.1~13.0 | 82 | 70 | 200 | 7.0 | 22 | 40 | 1.5 |
| 13.1~21.0 | 102 | 90 | 220 | 11.0 | 18 | 40 | 2.0 |
| 21.1~26.0 | 110 | 90 | 250 | 13.5 | 18 | 40 | 3.0 |
| 23.0~33.0 | 157 | 140 | 300 | 17 | | 70 | 5.7 |

Figure 8: Trunnion Type Suspension Clamp body

| | |
|---|---|
| Issued by: Head of Section, Standards | Authorized by: Head of Department, Standards |
| Signed:  | Signed:  |
| Date: 2015-09-17 | Date: 2015-09-17 |

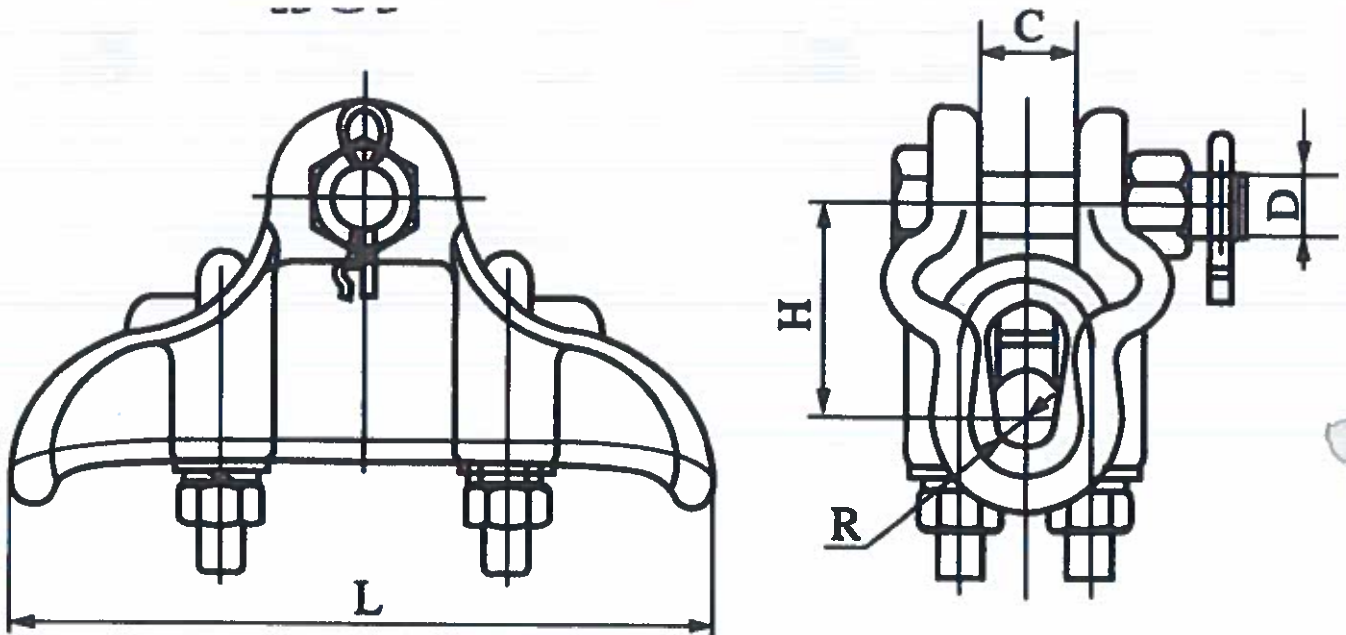

| Applicable conductor (mm) | Dimensions | | | | | Nominal failure load (kN) | Approximate weight (Kg) |
|---------------------------|------------|----|----|------|-----|---------------------------|-------------------------|
| | H | C | D | R | L | | |
| 5.1 – 12.5 | 50.5 | 23 | 16 | 8 | 166 | 40 | 1 |
| 12.4 – 18.3mm | 52.5 | 25 | 16 | 11.5 | 200 | 40 | 1.5 |
| 19.0 – 23.5 | 59.5 | 27 | 16 | 13.5 | 225 | 50 | 2.3 |
| 24.2 – 28.0 | 70 | 32 | 16 | 16 | 260 | 60 | 4.4 |

Figure 9: Aluminium Alloy Envelope Type Suspension Clamp for Overhead Transmission Line

| | |
|---|---|
| Issued by: Head of Section, Standards | Authorized by: Head of Department, Standards |
| Signed:  | Signed:  |
| Date: 2015-09-17 | Date: 2015-09-17 |

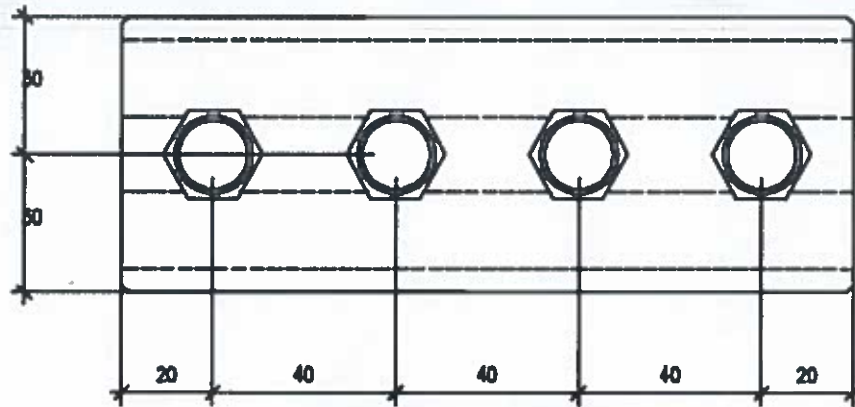

TOP ELEVATION

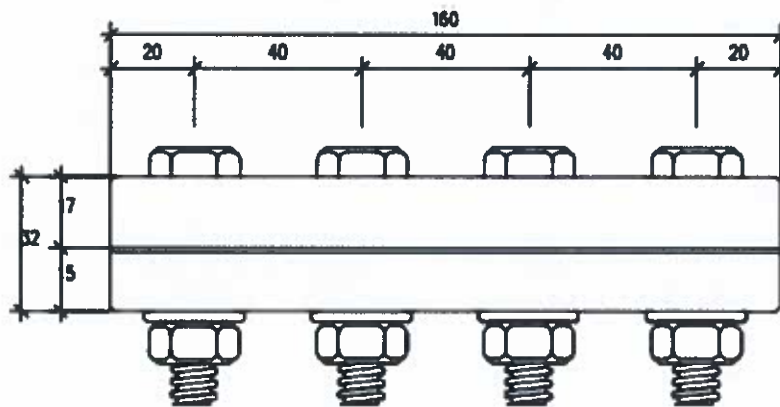

SIDE ELEVATION

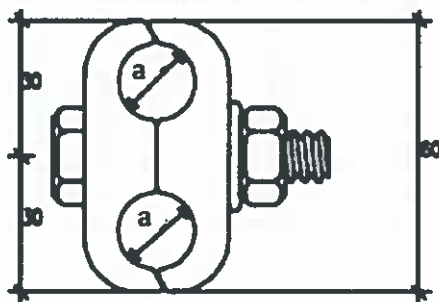

SIDE ELEVATION

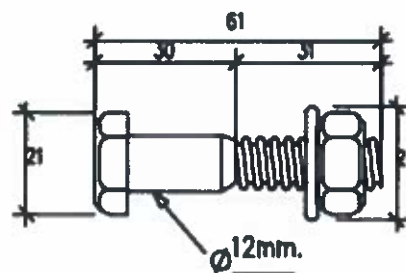

BOLT, WASHER AND NUT ELEVATIONS

Figure 10: Parallel Groove Clamp (4 Bolt) for conductors up-to 300mm²
Note: Dimension "a" shall be designed based on the sizes required on the tender.

Issued by: Head of Section, Standards

Authorized by: Head of Department, Standards

Signed: 
 Date: 2015-09-17

Signed: 
 Date: 2015-09-17

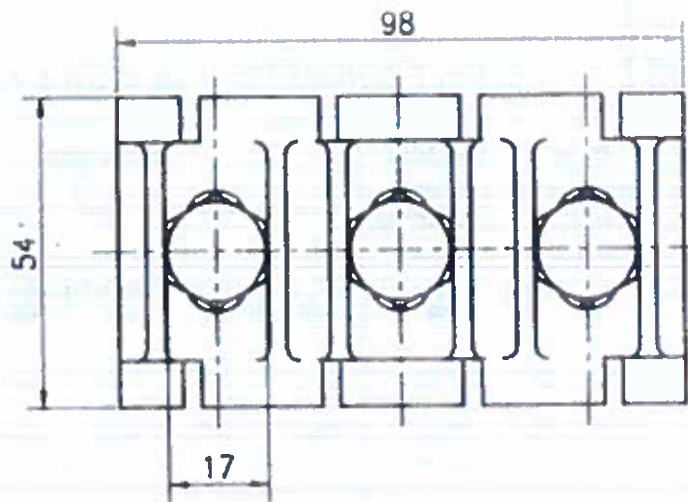
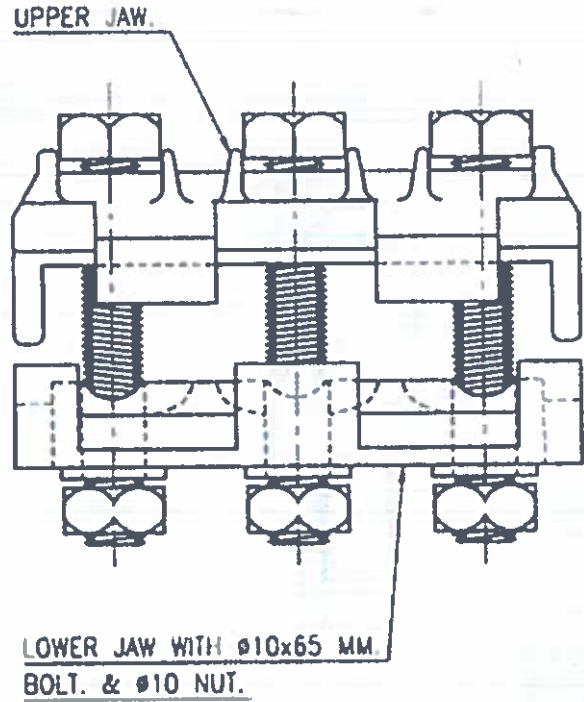
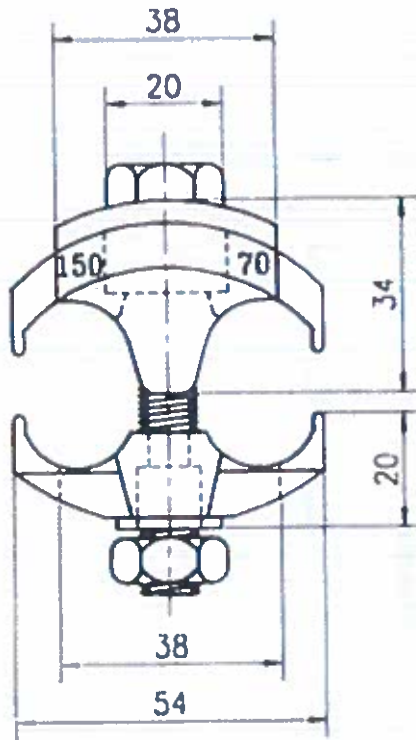

Figure 11: Parallel Groove Aluminium Alloy Clamps for 70-150 mm²

| | |
|---|---|
| Issued by: Head of Section, Standards | Authorized by: Head of Department, Standards |
| Signed:  | Signed:  |
| Date: 2015-09-17 | Date: 2015-09-17 |

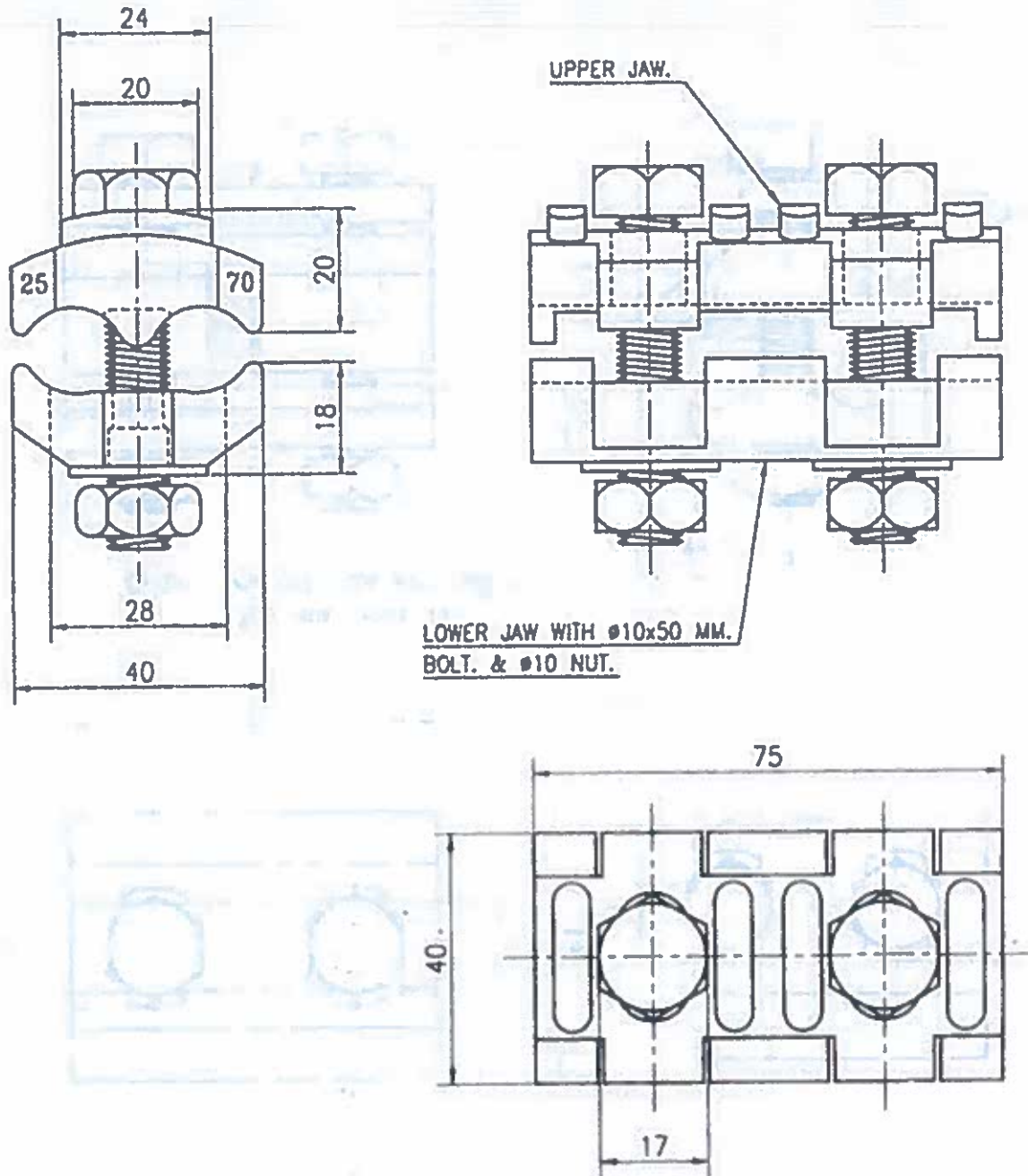

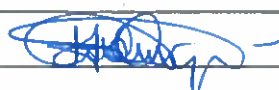
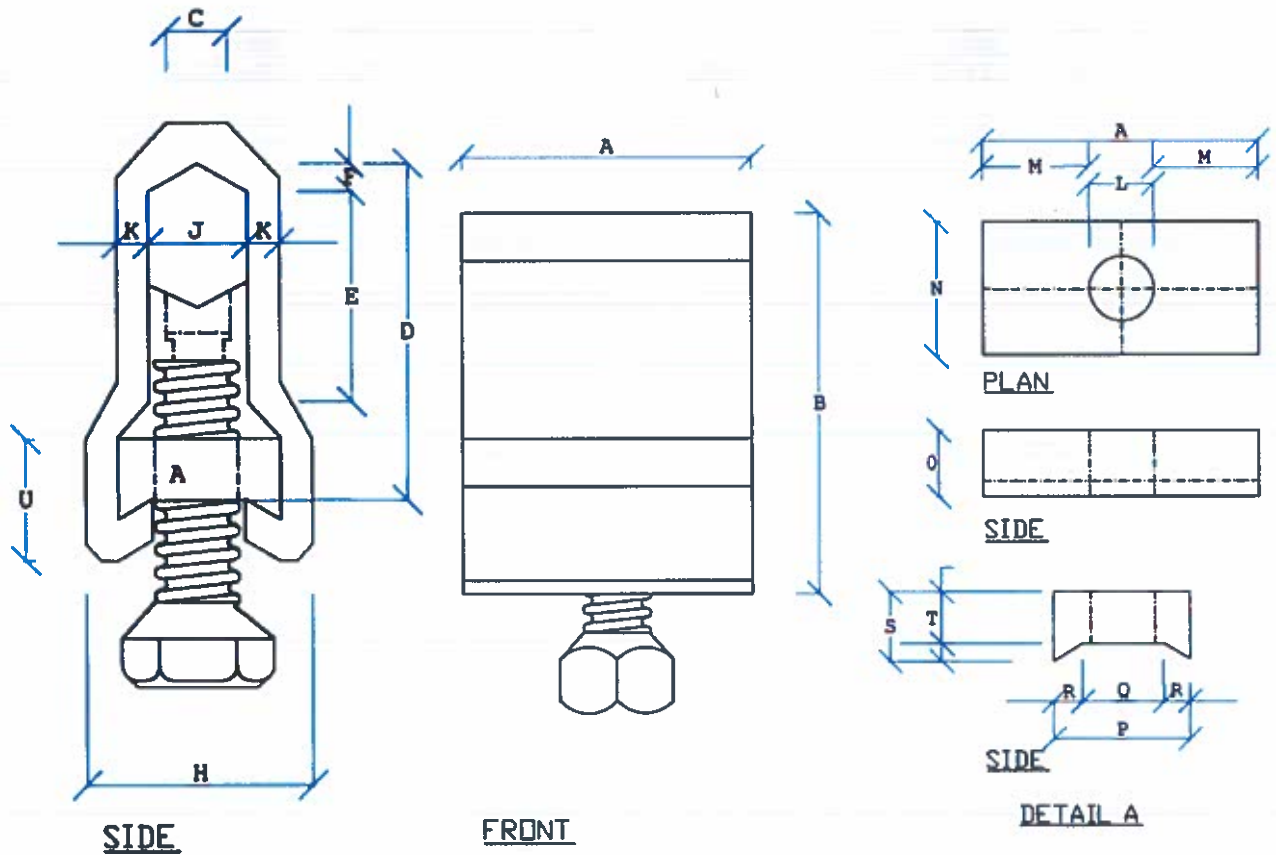

Figure 12: Parallel Groove Aluminium Alloy Clamps for 25-70 mm²



| | |
|---|---|
| Issued by: Head of Section, Standards | Authorized by: Head of Department, Standards |
| Signed:  | Signed:  |
| Date: 2015-09-17 | Date: 2015-09-17 |



| LINE TAP | A | B | C | D | E | F | G | H | J | K | L | M | N | O | P | Q | R | S | T |
|------------------------|----|----|---|----|----|-----|---|----|----|-----|----|----|----|----|----|----|---|----|---|
| For 50mm ² | 32 | 42 | 6 | 26 | 20 | 2.5 | 6 | 22 | 10 | 3 | 8 | 12 | 16 | 8 | 16 | 10 | 3 | 8 | 6 |
| For 100mm ² | 48 | 58 | 9 | 38 | 25 | 4 | 8 | 28 | 15 | 3.5 | 12 | 18 | 22 | 12 | 22 | 12 | 5 | 12 | 8 |

1. All dimensions are in millimetres
2. All the values are minimum values

Figure 13: Aluminium Line Tap

| | |
|---|---|
| Issued by: Head of Section, Standards | Authorized by: Head of Department, Standards |
| Signed:  | Signed:  |
| Date: 2015-09-17 | Date: 2015-09-17 |

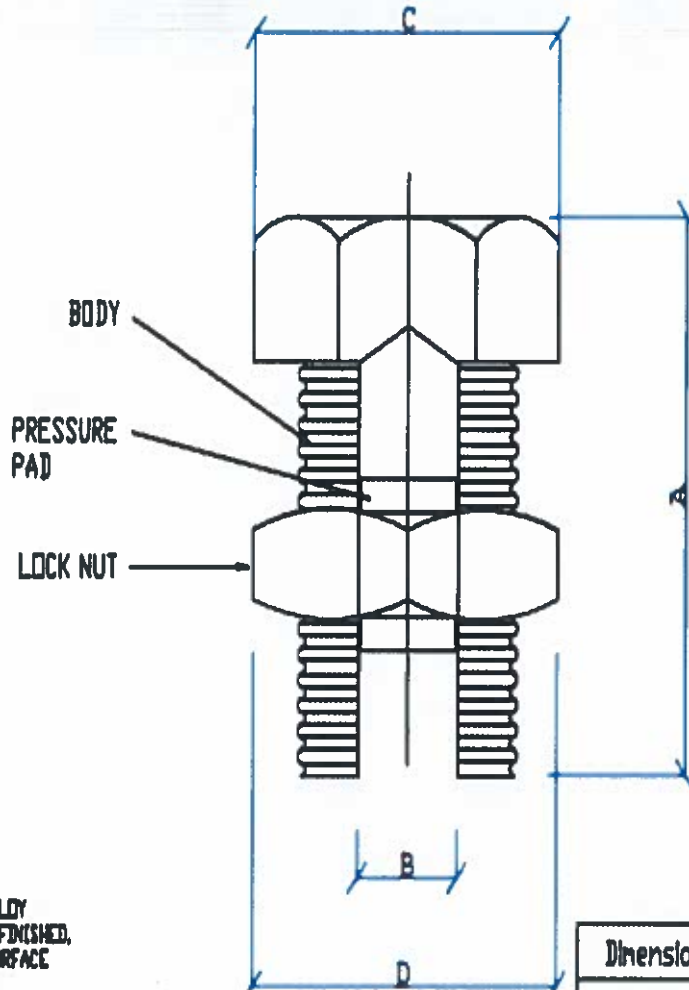



MATERIAL:
 HIGH STRENGTH CAST COPPER ALLOY
 (HIGH COPPER CONTENT) TONNED FINISHED,
 PRESSURE PADS WITH SERRATED SURFACE

| | | | | |
|-------------------|----------|----------|----------|----------|
| Dimensions | A | B | C | D |
|-------------------|----------|----------|----------|----------|

Table 4: Dimensions of copper connector line taps

| Conductor size/ Dimension (mm) | A | B | C | D |
|---------------------------------------|----------|----------|----------|----------|
| 10 – 25MM ² | 30 | 6.5 | 16 | 20 |
| 25 – 70MM ² | 42 | 12 | 24 | 32 |
| 750 – 120MM ² | 55 | 15 | 30 | 37 |
| 150MM ² | 74 | 19 | 48 | 52 |

Figure 14: Bi-metal connector (Bi-metal Line Tap)

| | |
|--|--|
| Issued by: Head of Section, Standards | Authorized by: Head of Department, Standards |
| Signed:  | Signed:  |
| Date: 2015-09-17 | Date: 2015-09-17 |

